

**PROGRESS REPORT GEOLOGIC MAP OF THE
RUSH VALLEY 30' x 60' QUADRANGLE,
TOOELE, UTAH, AND SALT LAKE COUNTIES, UTAH
(Year 2 of 3)**

by

Donald L. Clark¹, Stefan M. Kirby¹, and Charles G. Oviatt²

¹ Utah Geological Survey, P.O. Box 146100, Salt Lake City, UT 84114-6100

² Department of Geology, Kansas State University, Manhattan, KS 66506-3201

Disclaimer

This open-file release makes information available to the public during the review and production period necessary for a formal UGS publication. The map may be incomplete, and inconsistencies, errors, and omissions have not been resolved. While the document is in the review process, it may not conform to UGS standards; therefore, it may be premature for an individual or group to take actions based on its contents. Although this product represents the work of professional scientists, the Utah Department of Natural Resources, Utah Geological Survey, makes no warranty, expressed or implied, regarding its suitability for a particular use. The Utah Department of Natural Resources, Utah Geological Survey, shall not be liable under any circumstances for any direct, indirect, special, incidental, or consequential damages with respect to claims by users of this product.

This geologic map was funded by the Utah Geological Survey and U.S. Geological Survey, National Cooperative Geologic Mapping Program, through USGS STATEMAP award numbers 08HQAG0096 and G09AC00152. The views and conclusions contained in this document are those of the author and should not be interpreted as necessarily representing the official policies, either expressed or implied, of the U.S. Government.



**OPEN-FILE REPORT 568
UTAH GEOLOGICAL SURVEY**

a division of

**Utah Department of Natural Resources
2010**

GEOLOGIC UNIT DESCRIPTIONS

Alluvial deposits

- Qal **Alluvial deposits** (Holocene to upper Pleistocene) – Primarily clay, silt, and sand with some gravel lenses deposited by streams in channels and broad drainages; locally includes alluvial-fan, colluvial, low-level terrace, and eolian deposits; thickness generally less than about 20 feet (6 m).
- Qai **Alluvial silt deposits** (Holocene to upper Pleistocene) – Silt, clay, some sand, and minor gravel deposited by streams and sheet wash within former lagoonal areas related to Lake Bonneville shorelines; may include some thin fine-grained lacustrine deposits at bottom of lagoonal basins; thickness less than about 20 feet (6 m).
- Qat **Alluvial-terrace deposits** (Holocene to upper Pleistocene) – Sand, silt, clay, and gravel in terraces above floodplains; surfaces typically 10 feet (3 m) or more above adjacent drainages; thickness is 40 feet (12 m) or less.
- Qafy **Younger alluvial-fan deposits** (Holocene to upper Pleistocene) – Poorly sorted gravel with sand, silt, and clay; deposited by streams, debris flows, and flash floods on alluvial fans and in mountain valleys; includes alluvium and colluvium in canyon and mountain valleys; may include small areas of eolian deposits and lacustrine fine-grained deposits below the Bonneville shoreline; includes active fans and inactive fans younger than Lake Bonneville; locally Qafy spreads out along the wave-cut terraces and abuts Lake Bonneville shorelines, and Qafy also drapes over but does not completely conceal shorelines; thickness variable, to 100 feet (30 m) or more.
- Qafb **Alluvial-fan deposits, transgressive (Bonneville) phase of Lake Bonneville** (upper Pleistocene) – Poorly sorted gravel with sand, silt, and clay in alluvial fans that are graded to the Bonneville-level shoreline; may include small areas of eolian and colluvial deposits; incised by younger alluvial deposits; thickness variable, to 100 feet (30 m) or more.
- Qafo **Older alluvial-fan deposits** (upper to middle? Pleistocene) – Poorly sorted gravel with sand, silt, and clay; forms higher level deposits that predate Lake Bonneville and have been incised by younger alluvial deposits; may locally include small areas of lacustrine or eolian deposits; thickness variable, to 100 feet (30 m) or more.
- QTaf **Oldest alluvial-fan deposits** (lower Pleistocene? to Pliocene?) – Poorly sorted gravel with sand, silt, and clay; forms highest level deposits that have been incised by younger alluvial deposits and etched by Lake Bonneville; may locally include small areas of lacustrine or younger alluvial deposits; thickness variable, to 100 feet (30 m) or more.

Spring deposits

Qsm **Spring and marsh deposits** (Holocene) – Clay, silt, and sand that is variably organic-rich, calcareous, or saline; present in saturated (marshy) areas near springs and seeps near the center of valleys; thickness 0 to 30 feet (0-10 m).

Eolian deposits

Qe **Eolian deposits** (Holocene) – Windblown sand and silt in sheet and dune forms; mapped in Skull Valley and Cedar Valley; 0 to 20 feet (0-6 m) thick.

Qes **Eolian sheet sand deposits** (Holocene) – Windblown sand and silt deposited as sheets rather than well-developed dunes; generally thin with no distinct bedding; mostly silty, well-sorted, fine-grained quartz sand; less than 15 feet (5 m) thick.

Qed **Eolian dune sand deposits** (Holocene) – Well sorted sand in dunes and dune fields; mostly fine-grained quartz sand but also aggregates of clay, silt, and sand; present as parabolic, linear, dome, lunette, and shrub-coppice dunes (see Dean, 1978); larger dune fields may include a thin fringe of unmapped sheet sand; thickness to 50 feet (15 m).

Qei **Eolian silt** (Holocene) – Windblown silt mapped in three areas near the Bonneville shoreline on the southeast side of Rush Valley; less than 20 feet (6 m) thick.

Lacustrine deposits (post Bonneville lake cycle)

Qpm **Playa mud** (Holocene) – Poorly sorted clay, silt, and small amounts of sand with local accumulations of gypsum, halite, and other salts; present within the playa lake bed of Rush Lake and one other area in Rush Valley; thickness is 10 feet (3 m) or less.

Qlfy **Younger lacustrine fine-grained deposits** (Holocene) – Deposits adjacent to Rush Lake playa of clay, silt, and small amounts of sand; deposited by fluctuations of Holocene Rush Lake; thickness probably 15 feet (5 m) or less.

Qlsy **Younger lacustrine sand deposits** (Holocene) – Deposits adjacent to Rush Lake playa of sand with minor gravel; deposited by fluctuations of Holocene Rush Lake; thickness probably 15 feet (5 m) or less.

Lacustrine and Deltaic deposits (Bonneville lake cycle)

Table 1 presents ages and elevations of Lake Bonneville shorelines in the map area. Shoreline elevation ranges were determined from 1:24,000 scale topographic maps. These elevations generally increase from southeast to northwest across the map area due to isostatic rebound. Crittenden (1963) and Currey (1982) provided regional data on shoreline elevations and rebound. Several prominent erosional and depositional landforms related to Lake Bonneville exist in the map area, described below.

A small part of the Old River Bed crosses the southwest corner of the map area. The Old River Bed is an abandoned river valley present on the south part of Dugway Proving Ground and southward to the Sevier River southwest of Delta. This feature formed during the most recent episode of overflow from the Sevier basin (Lake Gunnison) northward to the Great Salt Lake basin (Lake Bonneville) (Oviatt, 1987; Oviatt and others, 1994). Where the river entered Lake Bonneville, a delta formed with numerous distributary channels (mapped by Clark and others, 2008); radiocarbon dating of the channels ranges from 8800 to 12,500 ¹⁴C years B.P. (about 10,000 to 13,000 calendar years B.P.) (Oviatt and others, 2003).

In the north-central part of the quadrangle, the Stockton Bar developed as a transverse barrier bar and spit complex between Tooele and Rush Valleys (Gilbert, 1890; Burr and Currey, 1988, 1992). Rush Valley contains the Bonneville-level shoreline and two sets of regressive-phase shorelines. These shorelines were initially described by Burr and Currey (1988, 1992) in conjunction with the Stockton Bar; co-author Oviatt also evaluated these shorelines in the field. The construction of the Stockton Bar (during the Bonneville transgression) caused the lake in Rush Valley to be cut off from the main body of Lake Bonneville; during the regression from the Bonneville highstand, the lake level in Rush Valley varied independently of the level in the rest of the Bonneville basin. The regressive shorelines present in Rush Valley (previously attributed to Lake Shambip, 5050 feet [1540 m] in elevation, and Lake Smelter, 5010 feet [1527 m] in elevation) do not coincide in elevation with the Provo or Gilbert levels of Lake Bonneville.

Qdg **Deltaic gravel** (upper Pleistocene) – Sand and gravel deposited near the mouth of the Sevier River in the Old River Bed area during the Bonneville lake cycle; well-sorted pebbly sand containing volcanic and sedimentary pebbles; cross-bedded and very thick bedded; regressive deposits were locally reworked by waves into a thin sheet with delta ridge crests; thickness to 50 feet (15 m).

Qlg **Lacustrine gravel** (upper Pleistocene) – Sandy gravel to boulders composed of locally derived rock fragments deposited in shore zones of Lake Bonneville; locally tufa-cemented and draped on bedrock; thickness variable, to 100 feet (30 m) or more.

Qls **Lacustrine sand** (upper Pleistocene) – Sand and silt deposited by transgressive and regressive phases of Lake Bonneville; thickness to 100 feet (30 m) or more.

Qlf **Lacustrine fine-grained deposits** (upper Pleistocene) – Sand, silt, marl, and calcareous clay of Lake Bonneville; thinly to very thick bedded; locally includes the white marl of Gilbert (1890) and other fine-grained lacustrine deposits; thickness to 100 feet (30 m) or more.

Glacial deposits

Qg **Glacial deposits, undifferentiated** (upper to middle? Pleistocene) – Till present in terminal, lateral, valley-head, and end moraines, and outwash composed of fine- to coarse-grained detritus derived from glaciated bedrock; present in several

cirques and valleys near Deseret Peak in the Stansbury Mountains and Flat Top Mountain of the Oquirrh Mountains (also see Rigby, 1958; Valora, 1968; Sorensen, 1982; Mulvey, 1985; Osborn and Bevis, 2001); locally includes unmapped landslides and rotational slumps, particularly in cirque basins, as well as alluvial and colluvial deposits; Osborn and Bevis (2001) reported these deposits are primarily of Angel Lake age (Great Basin equivalent to Pinedale of Middle Rocky Mountains) and that some are older; the Pinedale extended from about 12,000 to 24,000 years ago, while the older Bull Lake extended from about 128,000 to 186,000 years ago (Imbrie and others, 1984); up to 300 feet (90 m) thick.

Colluvial deposits

Qc **Colluvial deposits** (Holocene to upper Pleistocene) – Fine- to coarse-grained detritus derived from local bedrock; commonly includes talus in upper parts of deposits; may locally include lacustrine, alluvial, or eolian deposits; to 20 feet (6 m) or more thick.

Mass-movement deposits

Qmtc **Talus and colluvial deposits** (Holocene to upper Pleistocene) – Mixed talus and colluvium locally present on Tabbys Peak of Cedar Mountains, Camels Back Ridge, and Stanbury and Oquirrh Mountains; thickness to 15 feet (5 m) or more.

Qms **Landslide deposits** (Holocene to middle? Pleistocene) – Poorly sorted clay- to boulder-size material; generally characterized by hummocky topography, main and internal scarps, and chaotic bedding in displaced bedrock; undivided as to inferred age because new research shows that even landslides with subdued morphology (suggesting they are older and have not moved recently) may continue to creep or are capable of renewed movement (Francis Ashland, UGS, verbal communication, 2009); age and stability determinations require detailed geotechnical investigations; thickness highly variable.

Mixed-environment deposits

Qla **Lacustrine and alluvial deposits** (Holocene to upper Pleistocene) – Mixed and reworked, gravelly lacustrine and alluvial deposits on piedmont slopes; includes pre-Bonneville alluvial fans etched by waves in Lake Bonneville, and thin alluvial-fan deposits overlying fine- to coarse-grained lake sediments; grades from pebbly sand and silt to sandy pebble gravel; locally includes areas of thicker alluvial-fan deposits at surface in western Skull Valley; thickness locally exceeds 30 feet (10 m).

Qac **Alluvial and colluvial deposits** (Holocene to upper Pleistocene) – Primarily gravel, with sand, silt, and clay; forms aprons of small alluvial-fan and colluvial surfaces that spill out onto and grade into alluvial-fan deposits, and also present within upland valleys; thickness generally less than 20 feet (6 m).

Qea **Eolian and alluvial deposits** (Holocene) – Included below solely as stacked unit Qea/Qlf.

Human-derived deposits

Qh **Human disturbance** (Historical) – Deposits and disturbed areas from human development; Dugway Proving Ground area includes wastewater treatment lagoons, sanitary landfill, and Michael Army Airfield; also used for landfills on Skull Valley Indian Reservation and in Cedar Valley, several pits and quarries, tailings area north of Stockton Bar, and large mine areas (Mercur, Ophir, Bingham); thickness generally less than about 20 feet (6 m), but mine-dump deposits may exceed 200 feet (60 m) thick.

Stacked-unit deposits

Qei\Qal

Eolian silt over alluvial deposits (Holocene over Holocene to upper Pleistocene) – Windblown silt overlying alluvial deposits of clay, silt, sand, and some gravel in one area west of Ditto (formerly Dog) area at Dugway Proving Ground; cover unit thickness typically less than 10 feet (3 m).

Qei\Qlf

Eolian silt over lacustrine fine-grained deposits (Holocene over upper Pleistocene) – Windblown silt overlying lacustrine silt, clay, marl, and some sand over a large area of Government Creek basin and smaller areas of southeastern Rush Valley; surface commonly contains distinctive vegetation stripes (characteristic landforms of sheetflow plains in arid to semiarid regions) (Oviatt and others, 2003); may locally include areas of thicker eolian deposits; cover unit thickness typically less than 3 feet (1 m).

Qea\Qlf

Eolian and alluvial deposits over lacustrine fine-grained deposits (Holocene over upper Pleistocene) – Windblown silt deposited in sheets adjacent to and locally covering alluvial sand and gravel in unmapped channels overlying lacustrine marl and fine-grained deposits; locally saline or gypsiferous; forms one exposure in Government Creek basin that is part of extensive mudflats of southern Great Salt Lake Desert; may locally include small areas of thicker eolian deposits; cover unit thickness typically less than 15 feet (5 m) thick.

Qe\Qlf **Eolian deposits over lacustrine fine-grained deposits** (Holocene over upper Pleistocene) – Windblown sand and silt in sheet and dune forms overlying lacustrine silt, clay, marl, and some sand; present in Skull and Cedar Valleys; cover unit thickness typically less than 10 feet (3 m) thick.

Qes\Qlf

Eolian sheet sand deposits over lacustrine fine-grained deposits (Holocene over upper Pleistocene) – Windblown sand and some silt deposited in sheets;

overlies lacustrine silt, clay, marl, and some sand northeast of Little Granite Mountain; locally includes areas of thicker eolian deposits; cover unit thickness typically less than 6 feet (2 m).

Qed\Qlf

Eolian dune sand deposits over lacustrine fine-grained deposits (Holocene over upper Pleistocene) – Windblown dune sand and some silt overlying lacustrine sand, silt, marl, and clay; cover unit thickness typically less than 20 feet (6 m).

Qes\Qla

Eolian sheet sand deposits over lacustrine and alluvial deposits (Holocene over Holocene to upper Pleistocene) – Windblown sheet sand and silt overlying gravelly to fine-grained lacustrine and alluvial deposits; present at and northwest of Dugway and upland valley of White Rock-Post Hollow area; cover unit thickness typically less than 10 feet (3 m).

Qes\Qafy

Eolian sheet sand deposits over younger alluvial-fan deposits (Holocene over Holocene to upper Pleistocene) – Windblown sheet sand and silt covering younger alluvial fans west of Johnson Pass; cover unit thickness typically less than 10 feet (3 m).

Qes\Qafo

Eolian sheet sand deposits over older alluvial-fan deposits (Holocene over upper to middle? Pleistocene) – Windblown sheet sand and silt overlying older alluvial fans near Barlow Creek of the southwestern Stansbury Mountains; cover unit thickness typically less than 10 feet (3 m).

Qed\Qla

Eolian dune sand deposits over lacustrine and alluvial deposits (Holocene over Holocene to upper Pleistocene) – Windblown sand and some silt that forms well-developed dunes overlying gravelly to fine-grained lacustrine and alluvial deposits; locally well exposed in large gravel pit on southern margin of Cedar Mountains and north of the Dugway Proving Grounds airfield; cover unit thickness typically less than 20 feet (6 m).

Qlf\Qls

Lacustrine fine-grained deposits over lacustrine sand deposits (upper Pleistocene over upper Pleistocene) – Thin marl and reworked marl overlying deltaic sediments of mostly sand and some fine gravel deposited near the Stansbury shoreline; sandy beach ridges (distributary mouth bars) were formed by longshore sediment transport (Currey, 1996, in Geomatrix, 2001), and were previously mapped as faults by Sack (1993); exposures located on north side of Hickman Knolls on the Skull Valley Indian Reservation; cover unit thickness to 6 feet (2 m) or more.

Qed\Tac

Eolian dune sand deposits over andesitic and dacitic rocks of southern Cedar Mountains (Holocene over middle Eocene) – Windblown dune sand and silt overlying bedrock unit; locally includes small bedrock exposures; cover unit thickness typically less than 10 feet (3 m).

Qlg\Mh?

Lacustrine gravel over Humbug Formation? (upper Pleistocene over Upper Mississippian) – Sandy and pebbly gravel overlying bedrock exposures in Skull Valley at unnamed knoll north of Hickman Knolls, bedrock previously mapped by Moore and Sorensen (1979) as Upper Mississippian carbonate rocks (equivalent to Humbug and Deseret); cover unit thickness typically less than 15 feet (5 m).

Qlg\R **Lacustrine gravel over undifferentiated bedrock** (upper Pleistocene over Miocene? to Cambrian?) – Sandy and pebbly gravel overlying various bedrock units along western and southern margin of Cedar Mountains, on Camels Back Ridge, and in northern East Tintic Mountains; locally includes small bedrock exposures; cover unit thickness typically less than 15 feet (5 m).

Pre-Bonneville Deposits

Geomatrix (2001) reported on subsurface Quaternary deposits in the vicinity of the proposed Private Fuel Storage site on the Skull Valley Indian Reservation north of Hickman Knolls. This study identified the Promontory soil and associated deposits which represent a period of subaerial exposure during the interpluvial period between the Bonneville and Little Valley lake cycles from about 28 to 130 ka. Deposits representing the penultimate lake cycle, the Little Valley lake cycle (130 to 160 ka), were also encountered. The oldest Quaternary deposits reported in this investigation are pre-Little Valley alluvium and soil (older than 160 ka). These pre-Bonneville deposits are highly variable in thickness.

TERTIARY

Tsl **Salt Lake Formation** (Miocene) – Exposed in two areas: (1) South Willow Canyon area of the Stansbury Mountains, and (2) central Rush Valley, and known from the subsurface in Skull Valley. In *Skull Valley*, trenching at the proposed Private Fuel Storage site exposed predominantly claystone and tuffaceous siltstone with interbeds of siliceous vitric ash (tuff) and minor gravelly sandstone (Geomatrix, 2001); based on geochemical correlation of volcanic ashes, ages reported for this unit (table 2) were about 6 Ma (unknown tephra) and 6.31 ± 0.04 Ma (Walcott tuff) (SWEC, 1997; Geomatrix, 2001; M. Perkins, University of Utah, written communication, November 18, 2009); maximum subsurface thickness encountered may be 90 feet (27 m), total thickness unknown. *Stansbury* exposures are interbedded tuffaceous sandstone and conglomerate that weather rusty-orange with carbonate, igneous, and quartzite pebbles in a fine sandy calcareous matrix (Rigby, 1958; Copfer and Evans, 2005); Perkins and

others (1998) geochemically correlated a tephra in this exposure to the Cougar Point Tuff unit XIII ash, which has an $^{40}\text{Ar}/^{39}\text{Ar}$ age of 10.94 ± 0.03 Ma (table 2); exposed thickness to about 1000 feet (300 m), total thickness unknown. **Rush Valley** outcrops include varied lithologies of tan, pale-gray, and white interbedded tuffaceous sandstone, limestone, calcareous sandstone, gritty or pebbly sandstone, sandy mudstone, siltstone, marl and claystone; locally the tuffaceous sandstone is poorly consolidated waterlain sandy ash in intervals 60 to 100 feet (23-30 m) thick; yielded tephra interpolation and correlation ages of 6.6 ± 0.03 and 9.8 ± 0.23 Ma (table 2) (Perkins and others, 1998); regional ages on the Salt Lake Formation extend from about 6 to 16.2 Ma (Perkins and Nash, 2002; M.E. Perkins, University of Utah, written communication, August 2, 2010); unit is up to 4200 feet (1280 m) thick (Kirby, 2010a, 2010c).

IGNEOUS AND SEDIMENTARY ROCKS OF THE SOUTHERN CEDAR MOUNTAINS AND SOUTHERN STANSBURY MOUNTAINS

Geochemical and age data for Tertiary igneous rocks are presented in tables 3 and 4, NMGRL and UGS (2006), Clark (2008), and UGS and NMGRL (2009a, 2009b). Rock names are generally from the total alkali-silica classification diagrams for volcanic rocks (Le Bas and others, 1986) and plutonic rocks (Middlemost, 1994). Descriptions and thickness data from Clark and others (2008) and this study.

- Trr **Rhyolite of Rydalch Canyon area** (Miocene?) – Light-gray and very pale orange rhyolitic ash-flow tuff exposed south and east of Rydalch Canyon in southern Cedar Mountains; about 25% phenocrysts of feldspar, quartz, hornblende, and biotite; appears to overlie map unit Tac; new radiometric age pending; exposed thickness to 650 feet (200 m).
- Ts **Tertiary strata** (Oligocene? to Eocene?) – Grayish-orange, very pale orange, and moderate-orange-pink lacustrine limestone that is locally oncolitic, moderately crystalline, indistinctly to thin bedded, and underlain by moderate-reddish-orange tuffaceous sandstone; mapped in one area southwest of Dugway (English Village); exposed thickness about 100 feet (30 m).
- Tdi **Dacitic intrusions of Little Granite Mountain and White Rock** (middle Eocene) – Light-gray weathering to white and yellowish-gray porphyritic dacite; phenocrysts (~25%) of plagioclase, quartz, biotite, and amphibole (0.5-2 mm long average); groundmass is intergrowth of plagioclase, potassium feldspar, and quartz (Maurer, 1970; Moore and Sorensen, 1977); $^{40}\text{Ar}/^{39}\text{Ar}$ ages of 40.95 ± 0.32 Ma (hornblende) and 39.56 ± 0.10 Ma (biotite, less reliable) for Little Granite Mountain and 38.69 ± 0.10 Ma (sanidine) for White Rock (UGS and NMGRL, 2009a, 2009b); exposures to 9500 feet (2900 m) across.
- Tac **Andesitic and dacitic rocks of southern Cedar Mountains** (middle Eocene) – Dark- to light-gray and pale-red lava flows interlayered with lahars and less

common tuffs; lava flows are porphyritic to aphanitic, with phenocrysts of feldspar, quartz, and biotite; lahars contain clasts of intermediate volcanic rocks to 4 feet (1 m) across; variously welded ash-flow tuffs contain phenocrysts of feldspar, hornblende, and biotite; calc-alkaline affinities are similar to those of other Oligocene-Eocene rocks in the region (Clark, 2008); erupted from local vents mapped as Taci; $^{40}\text{Ar}/^{39}\text{Ar}$ age of 38.17 ± 0.47 , and also ages (from adjacent map area) of 41.73 ± 0.24 Ma (hornblende) and 40.66 ± 0.45 (groundmass) (UGS and NMGR, 2009b); exposed thickness to 1200 feet (370 m).

Taci **Andesitic intrusions of southern Cedar Mountains** (middle Eocene) – Dark-gray porphyritic to aphanitic andesitic intrusions associated with local vents for extrusive calc-alkaline volcanic rocks (Tac); phenocrysts of feldspar, hornblende, and lesser biotite; columnar jointing of exposures common; $^{40}\text{Ar}/^{39}\text{Ar}$ age of 40.61 ± 0.78 Ma (groundmass) from Tabby's Peak (UGS and NMGR, 2009b); exposures to 1600 feet (490 m) across.

Tvs **Intermediate volcanic rocks of Stansbury Mountains** (middle Eocene) – Interlayered lahars, debris flows, lava flows, and tuff described by Davis (1959); light-gray lahars are thin to very thick bedded with mostly cobble-size clasts, and gray to pale-red debris flows are indistinctly bedded with shattered clasts to boulder size; lahars and debris flows contain clasts of pale-red and moderate- to dark-gray intermediate volcanic rocks; latitic lava flows are moderate-gray weathering to light gray brown with small phenocrysts of plagioclase and biotite; tuff is pumice rich; exposures in South Willow Canyon area of Stansbury Mountains; Moore and McKee (1983) reported K-Ar ages of about 39 to 42 Ma north of the map area; exposed thickness to about 1400 feet (430 m).

IGNEOUS AND SEDIMENTARY ROCKS OF SOUTHERN OQUIRRH MOUNTAINS, SOUTH MOUNTAIN, AND WESTERN TRAVERSE MOUNTAINS

These rocks are present at and near the Bingham, Stockton (Rush Valley), Ophir, and Mercur mining districts. Bingham district rocks were divided into four informal compositional suites by Waite (1996) and Waite and others (1997): (1) younger volcanic suite, (2) older volcanic suite, (3) nepheline minette-shoshonite suite (within the older volcanic suite), and (4) Bingham intrusive suite. Biek and others (2005) and Biek (2006a) informally referred to the younger suite as the Volcanic and Intrusive Rocks of the West Traverse Mountains, and combined the latter three suites as the Volcanic and Intrusive Rocks of the Bingham Canyon Suite. We also group the igneous rocks into younger and older suites, and further separate the suites into extrusive and sedimentary rocks, and intrusive rocks. The terminology for the intrusive rocks of the Bingham district (after Lanier and others, 1978) is based on historic usage at Bingham mine (for the purpose of separating similar rock units); it is entrenched and does not necessarily reflect their geochemical compositions and newer geochemically-based rock classifications. For geochemical and age data, see Waite (1996), Waite and others

(1997), Pulsifer (2000), Maughan (2001), Biek and others (2005), Biek (2006b); also refer to table 4. Unit thickness data is from Biek and others (2005) and this study.

Younger Volcanic and Intrusive Suite (lower Oligocene to upper Eocene, ~30-37 Ma)
Younger Extrusive and Sedimentary Rocks

Tvbs **Younger volcanic breccia** (lower Oligocene) – Dark-gray to black, angular to subangular, pebble- to boulder-size clasts of monolithic, intermediate-composition volcanic rocks set in a well-lithified matrix of reddish-brown devitrified glass and lithic and crystal fragments; clasts generally make up more than 50% of the rock and contain phenocrysts of plagioclase, hornblende, and biotite in dark-gray to black glassy matrix; forms broad sloping surface of South Mountain and Black Ridge in the west Traverse Mountains; K-Ar age on clast of 30.7 ± 0.9 Ma (Moore, 1973); thickness to 300 feet (90 m).

Tvfs **Younger lava flows** (lower Oligocene) – Intermediate composition lava flows that are strongly flow foliated (typically subvertical) with reddish-brown and dark-gray to black layering; underlies and compositionally identical to volcanic breccia unit (Tvbs) at South Mountain in west Traverse Mountains; no age data; maximum exposed thickness likely exceeds 1000 feet (300 m).

Tvfb **Intermediate lava flows of Black Ridge** (lower Oligocene) – Dark-gray to pinkish-gray porphyritic intermediate-composition lava flows with common phenocrysts of plagioclase and rare to common biotite and hornblende; locally flow banded; forms boulder-covered slopes; likely derived from volcanic centers of west Traverse Mountains including Step Mountain, South Mountain, and nearby smaller vents; no radiometric age data, but overlies Tvfb; exposed thickness may exceed 600 feet (180 m).

Tvlb **Lahars and debris flows of Black Ridge** (lower Oligocene) – Pebbles to boulders of intermediate-composition volcanic rocks and uncommon quartzite pebbles in a matrix of white to light-gray crystal lithic tuff; contains some thin, poorly exposed lava flows; forms poorly exposed slopes covered with resistant volcanic clasts in Black Ridge area of west Traverse Mountains; $^{40}\text{Ar}/^{39}\text{Ar}$ ages from near base of unit are 31.68 ± 0.24 Ma from adjacent map area (Biek, 2005) and 32.12 ± 0.14 Ma (Deino and Keith, 1997); maximum thickness likely exceeds 1000 feet (300 m).

Trf **Rhyolitic lava flows of Tickville Gulch** (lower Oligocene) – Rhyolite vitrophyre flows and lesser blocky flow breccia of green, pink, white, and black colors; flows contain phenocrysts of biotite and plagioclase in a glassy groundmass and are locally altered and chalky; probably erupted from concealed vent near Tickville Wash; K-Ar age of 31.2 ± 0.9 Ma (Moore and others, 1968; Moore, 1973); thickness may exceed 1500 feet (460 m).

Tvfa **Basaltic andesite lava flow** (lower Oligocene) – Dark-gray, very fine grained basaltic andesite flow with abundant reddish-brown cinders and local volcanic

bombs; contains small olivine phenocrysts altered to iddingsite; forms deeply eroded vent area at Camp Williams; somewhat disturbed $^{40}\text{Ar}/^{39}\text{Ar}$ age of 32.86 ± 0.48 Ma (Biek and others, 2005); exposed thickness to 120 feet (35 m).

Younger Intrusive Rocks

Tdio **Dacitic dike** (early Oligocene) – Light-gray dacite porphyry with phenocrysts of plagioclase, hornblende, and biotite in a fine-grained matrix; present near Oak Springs Hollow of western Traverse Mountains; $^{40}\text{Ar}/^{39}\text{Ar}$ age of 32.05 ± 0.13 Ma (Biek and others, 2005); 75 to 90 feet (23-27 m) thick.

Tri **Rhyolitic intrusions** (early Oligocene? to late Eocene) – Rhyolitic intrusions of Shaggy Peak (Rose-Butterfield Canyon area), Tickville Gulch area, Dry Mountain-Ophir area, and Eagle Hill-Mercur area. Shaggy Peak plug or dome is light- to medium-gray porphyritic rhyolite that contains a border phase with abundant plagioclase, quartz, and biotite phenocrysts and generally near vertical flow foliations, and an interior phase with slightly larger phenocrysts and little or no flow foliation (Biek, 2006a); $^{40}\text{Ar}/^{39}\text{Ar}$ age of 35.49 ± 0.13 Ma (Biek and others, 2005) and prior K-Ar age of 33.0 ± 1.0 Ma (Moore, 1973). Tickville Gulch intrusion is white, altered and chalky weathering, with phenocrysts of quartz common. Eagle Hill Rhyolite is white, tan, and pink rhyolite and rhyolite porphyry; usually aphanitic with ~1% phenocrysts of quartz and rare biotite, locally flow banded; occurs as dikes and sills at Mercur (Mako, 1999) and Ophir (Laes and others, 1997); K-Ar age of 31.6 ± 0.9 Ma (Moore, 1973).

Tai **Andesitic intrusion** (late Eocene) – Medium-gray andesite porphyry with abundant plagioclase phenocrysts and common hornblende and minor biotite in a medium-grained matrix; forms plug that includes two dikes with subhorizontal, columnar cooling joints at Step Mountain near mouth of Rose Canyon (Biek, 2006a); $^{40}\text{Ar}/^{39}\text{Ar}$ age of 36.26 ± 0.18 Ma (Biek and others, 2005).

Tpqqmi **Porphyritic quartz monzonite intrusions** (late to middle Eocene) – Intrusions at the former Lark townsite and Porphyry Hill area. Lark intrusion is light- to medium-gray granodiorite (dacite) porphyry with abundant phenocrysts of plagioclase and biotite and lesser hornblende in fine-grained groundmass; typically weathers to grussy or clayey soils; present near mouth of Butterfield Canyon near former Lark townsite (Swenson, 1975; Biek and others, 2005); prior K-Ar ages from Bingham tunnel portal (adjacent to map area) of 36.9 ± 0.9 Ma (hornblende) and 36.9 ± 1.0 Ma (biotite) (Moore and others, 1968). Porphyry Hill-area intrusions are medium gray quartz monzonite porphyry with small phenocrysts of K-feldspar, plagioclase, biotite, and quartz in a fine-grained groundmass of predominantly K-feldspar; present as small dikes and sills on Porphyry Hill and Porphyry Knob north of Mercur (Mako, 1999); K-Ar age of 36.7 ± 0.5 Ma from Porphyry Hill (Moore and McKee, 1983).

Older Volcanic and Intrusive Suite (middle Eocene, ~37-40 Ma) – Data indicate that the older suite rocks are largely comagmatic with the Bingham intrusive complex (Waite and

others, 1997) and contain significantly higher chromium and barium concentrations and contain more magnetic minerals than the younger suite (Pulsifer, 2000).

Older Extrusive and Sedimentary Rocks

Tvfo **Nepheline minette and shoshonite lava flows** (middle Eocene) – Dark-gray minette with abundant phenocrysts of olivine and minor phlogopite and pyroxene, and another minette with little olivine and more abundant phlogopite and pyroxene; also includes red, aa-type, shoshonite and olivine latite lava flows with abundant small phenocrysts of olivine, pyroxene, and biotite (Pulsifer, 2000; Maughan, 2001; Biek and others, 2005); exposed near the Rose-Butterfield Canyon area of Oquirrh Mountains; minette $^{40}\text{Ar}/^{39}\text{Ar}$ age of 37.82 ± 0.14 Ma (Deino and Keith, 1997) and prior K-Ar age of 38.5 ± 0.3 Ma (Moore and McKee, 1983); exposed thickness to 150 feet (45 m).

Tsu **Lacustrine strata** (middle Eocene) – Yellowish-brown, brownish–gray, and light-gray, typically thin-bedded and tuffaceous mudstone, siltstone, oncolitic limestone, and volcanoclastic sandstone; locally silicified; one exposure present near Butterfield Canyon; interlayered with Tvfo and Tvlo; exposed thickness about 150 feet (45 m) (Biek and others, 2005; Biek, 2006a).

Tvfou **Older intermediate lava flows** (middle Eocene) – Dark-gray lava flows of intermediate composition derived from Bingham intrusive complex; interlayered with and difficult to differentiate from the older lahars and debris flows (Tvlo); present between Butterfield and Rose Canyons; no age data; exposed thickness likely exceeds 1000 feet (300 m).

Tvlo **Older lahars and debris flows** (middle Eocene) – Pebbles to boulders of intermediate-composition volcanic rocks in a matrix of lithic and crystal fragments; locally contains mostly mafic clasts or lenses of quartzitic and calcareous sandstone clasts derived from adjacent Oquirrh outcrops; contains some thin discontinuous lava flows of intermediate composition (Pulsifer, 2000; Maughan, 2001; Biek and others, 2005); generally forms rubbly slopes between Butterfield and Rose Canyons and along south flank of Bingham mine, and on northeast flank of South Mountain; Bingham area $^{40}\text{Ar}/^{39}\text{Ar}$ ages of 38.68 ± 0.13 Ma from waterlain tuff near top of unit (Maughan, 2001) and 39.18 ± 0.11 Ma from clast near base of unit (Deino and Keith, 1997); thickness may exceed 4000 feet (1200 m).

Older Intrusive Rocks

Tqmi **Quartz monzonite porphyry intrusion** (middle Eocene?) – Altered part of the Soldier Canyon stock with K-spar and quartz phenocrysts and limonite staining (Lufkin, 1965); Laes and others (1997) suggested intrusion may be related to Bingham stock, which has a K-Ar age of 37.6 ± 0.07 (Moore, 1973).

Tmi **Monzonite intrusions** (middle Eocene) – Monzonite intrusions of Spring Gulch, Soldier Canyon, and Bingham (Last Chance) areas. Fine- to medium-grained,

equigranular, containing augite, hornblende, biotite, and magnetite, and ranging compositionally from diorite to quartz monzonite; the Spring Gulch monzonite crops out just north of the Calumet mine east of Stockton (Krahulec, 2005); Tmi also present at the Soldier Canyon stock (Lufkin, 1965) and near the axis of Long Ridge anticline (Laes and others, 1997; Tooker, 1992); the monzonites of the Stockton/Rush Valley district are similar in appearance and composition to the Last Chance stock in the Bingham district (Krahulec, 2005) which has a prior K-Ar age of 38.6 ± 0.18 Ma (Moore, 1973), U-Pb age of 38.55 ± 0.19 Ma, and $^{40}\text{Ar}/^{39}\text{Ar}$ age of 38.40 ± 0.16 Ma (Parry and others, 2001); K-Ar age of 38.0 ± 1.1 Ma (Moore, 1973) from monzonite porphyry stock of the Calumet Mine area.

- Tli **Latite to dacite porphyry sills and dikes** (middle Eocene) – Greenish-gray to dark-gray latite to dacite porphyry with abundant phenocrysts of plagioclase and hornblende and lesser biotite; present north of Butterfield and Middle Canyons in Oquirrh Group strata of south flank of Bingham mine area; K-Ar age of 37.1 ± 1.1 Ma (Moore, 1973), $^{40}\text{Ar}/^{39}\text{Ar}$ age of 38.84 ± 0.19 Ma (Deino and Keith, 1997); 0 to about 400 feet (120 m) thick.
- Tqli **Quartz latite porphyry dikes** (middle Eocene) – Fine-grained, biotite, quartz latite porphyry with large potassium feldspar phenocrysts (to 1 inch [3 cm]) and some augite; named the Raddatz porphyry (along Continental fault) in the Stockton/Rush Valley district where it forms dikes (Krahulec, 2005), and also may crop out on Bald Mountain (north of Ophir); K-Ar age of 38.6 ± 1.1 Ma (Moore, 1973), $^{40}\text{Ar}/^{39}\text{Ar}$ age on Raddatz dike of $39.4 \text{ Ma} \pm 0.34 \text{ Ma}$ age (Kennecott, unpublished date in Krahulec, 2005).
- Tbi **Basalt sill** (middle Eocene) – Dark-gray basalt sill intruding Oquirrh strata on South Mountain; may be related to unit Tvfo; K-Ar age of 40.1 ± 0.5 Ma (Moore and McKee, 1983); previously called a nepheline basalt (Gilluly, 1932; Moore and McKee, 1983); only largest sill mapped, about 50 feet (15 m) thick.

IGNEOUS AND SEDIMENTARY ROCKS OF THE VERNON HILLS

Unit descriptions and thickness data from Kirby (2010a, 2010b).

TERTIARY

- Tbav **Basaltic andesite** (Miocene?, Oligocene?, Eocene?) – Dark-gray basaltic andesite lava flow with 20% olivine phenocrysts; weathered and poorly exposed; no age data; exposed thickness is 40 feet (13 m).
- Tdv **Dacite** (Eocene?) - Light-gray to reddish-brown porphyritic dacite and trachydacite lava flows; phenocrysts (30%) of plagioclase and minor hornblende, and dark-gray lithic fragments; new radiometric age date pending; maximum exposed thickness is 30 feet (10 m).

Trv **Rhyolite** (Eocene?) – White to light-gray and locally dark-gray, rhyolitic ash-flow tuff; ranges from densely welded and flow banded to unwelded and ashy; phenocrysts (15%) of quartz; contains angular and subangular lithic fragments of older volcanic rocks (to 10 mm) and black vitrophyre (to 20 mm). Also pale-red to gray porphyritic welded tuff; phenocrysts (30%) include plagioclase, biotite, hornblende; densely welded with flow banding; prior K-Ar biotite age of 38 ± 0.5 Ma (Moore and McKee, 1983), new radiometric age dates pending; exposed thickness is 40 to 100 feet (12-30 m).

IGNEOUS AND SEDIMENTARY ROCKS OF THE NORTHERN EAST TINTIC MOUNTAINS

Unit descriptions, age and thickness data from Christiansen and others (2007), Biek and others (2009), McKean and others (in preparation), Allen (in preparation), and this study.

- Tj **Jasperoid** (Tertiary?) – Silicified replacement breccias, commonly pink and/or dark red to dark red brown; appears to be associated with volcanism; variable thickness.
- Tvm **Minette** (Tertiary) – Poorly consolidated rock with minette-like characteristics in one exposure at mouth of Black Rock Canyon (Boulter Peak quadrangle); 30-40% phenocrysts of brassy hexagonal biotite, and also Fe-Ti oxides, apatite, clustered olivine, possible carbonate; no age data; exposed thickness less than 30 feet (10 m).
- Tdm **Mafic dikes** (Tertiary) – Aphanitic, dense intrusions with 10-25% phenocrysts of olivine, pyroxenes, and altered micas; three small exposures in the Boulter Peak quadrangle; no age data; exposed thickness less than 30 feet (10 m).
- Tb **Mosida Basalt** (Miocene) – Medium-dark-gray, porphyritic, trachybasalt lava flow; contains phenocrysts of olivine, plagioclase, and clinopyroxene; vent is unexposed near Soldiers Pass in southern Lake Mountains (east of map area); represents one of the oldest basaltic magmas of the eastern Great Basin, with $^{40}\text{Ar}/^{39}\text{Ar}$ ages of 19.47 ± 0.17 and 19.65 ± 0.15 Ma (Christiansen and others, 2007), additional Ar age pending; 0 to 120 feet (35 m) thick.

Unconformity

- Tpc **Pinyon Creek Conglomerate** (upper or lower Oligocene?) – Agglomerate with reddish brown to gray clasts up to boulder size probably derived from the Laguna Springs Volcanic Group; distinctly bedded (beds 1.5 to 10 feet [0.5-3 m] thick) with some beds of nearly all fine ash and small volcanic fragments and others with both fine and coarse volcanic fragments (Morris and Lovering, 1961); unit

- includes a dark-gray pillow lava breccia (shoshonite) in one small exposure near Chimney Rock Pass; thickness is greater than 150 feet (>50 m).
- Tfb **Mafic lava of Broad Canyon** (lower Oligocene?) – Light gray to black, vesicular, porphyritic to aphanitic, shoshonitic lava flow with 10% megacrysts of anorthoclase and 5-15% phenocrysts of augite, and highly altered micas that are replaced with Fe-oxides and olivine; thickness is 30 to 100 feet (10-30 m).
- Tlsl **Laguna Springs Volcanic Group, lava flow unit** (lower? Oligocene) – Andesite to trachyandesite lava flows that are reddish-brown, purplish-gray and gray; lavas are dense and commonly vitrophyric, with large phenocrysts (30-40%) of plagioclase, sanidine, biotite, hornblende, and clinopyroxene; $^{40}\text{Ar}/^{39}\text{Ar}$ age pending; exposed thickness to 750 feet (230 m).
- Tlsa **Laguna Springs Volcanic Group, tuff unit** (lower? Oligocene) – A heterogeneous unit composed mostly of ash and tuffaceous material of varying grain and clast sizes; dark-reddish-brown andesite to trachyandesite tuffs; phenocrysts (10-20%) of plagioclase, biotite, and hornblende; no age data, but underlies Tlsl; exposed thickness to 400 feet (120 m).
- Tlst **Laguna Springs Volcanic Group, tuff of Twelvemile Pass unit** (lower Oligocene) – Intensely welded tuff that is reddish brown to dark reddish brown; trachyandesite to trachydacite with phenocrysts (10-20%) of plagioclase, biotite, hornblende, and clinopyroxene; also with flattened pumice lapilli (5-10%) (lapilli 6-20 cm and pumice 1-2 cm diameter); preliminary $^{40}\text{Ar}/^{39}\text{Ar}$ age of 32.66 Ma (E.H. Christiansen, Brigham Young University, verbal communication, January 2010); exposed thickness to 125 feet (40 m).
- Tsw **Soldiers Pass Formation, White Knoll Member** (lower Oligocene) – White and pale-yellowish-orange limestone that weathers yellowish gray, with interbedded very pale orange, white, and pale-red claystone; partly coeval with map unit Tsb, but probably spans a relatively large age range; thickness is 0 to 10 feet (3 m).
- Tsb **Soldiers Pass Formation, Breccia member** (lower Oligocene) – Gray, white, brown, and pale-red shoshonite lava flow; exposed mostly as distinctive, brecciated, carbonate-impregnated lava, but also occurs as gray and pale-red, locally vesicular lava flow; interfingers with and partly overlain by the White Knoll Member (Tsw); forms ledges and rounded knobs; $^{40}\text{Ar}/^{39}\text{Ar}$ age of 33.73 ± 0.65 Ma (Christiansen and others, 2007); exposed thickness is less than 40 feet (12 m).
- Tsc **Soldiers Pass Formation, Chimney Rock Pass Tuff Member** (upper Eocene) – Yellowish-gray, porphyritic, rhyolitic ash-flow tuff; contains about 10% phenocrysts of quartz, plagioclase, sanidine, biotite, and Fe-Ti oxides in a glassy groundmass; also contains conspicuous pumice (10-15%, 1-5 cm) and lithic (10-15%, 1-4.5 cm) fragments; vent unknown, but may be near Black Point in

southern Lake Mountains (east of map area); $^{40}\text{Ar}/^{39}\text{Ar}$ sanidine age of 34.73 ± 0.08 Ma from Chimney Rock Pass (Christiansen and others, 2007; Biek and others, 2009) and preliminary $^{40}\text{Ar}/^{39}\text{Ar}$ age of 34.61 ± 0.2 Ma (E.H. Christiansen, Brigham Young University, verbal communication, January 2010); exposed thickness to 100 feet (30 m).

Ttlr Tintic Mountain Volcanic Group, Latite Ridge Latite (upper Eocene) – Dark-reddish-brown to brown, densely welded, trachytic tuff with phenocrysts (15-20%) of plagioclase and biotite in a glassy groundmass; tuff is rich in lithic fragments (15-20%, ~1 cm), pumice (10-15%), and black flattened pumice lapilli (5-15 cm); $^{40}\text{Ar}/^{39}\text{Ar}$ biotite age of 34.64 ± 0.17 Ma (UGS and NMGR, 2007) from Tintic Mountain quadrangle (south of map area); exposed thickness is to 150 feet (45 m).

Tp Packard Quartz Latite, undivided (upper Eocene) – Light-gray to pink, non-welded to welded rhyolite ignimbrite with large and abundant phenocrysts (30-40%) of quartz, sanidine, plagioclase, and biotite; bi-pyramidal quartz phenocrysts are the distinguishing characteristic; also contains pumice (1-5%, 1-4 cm) and lithic fragments (1-5%, 1-4 cm) that are not as abundant as in the Chimney Rock Pass Tuff Member of the Soldiers Pass Formation; preliminary $^{40}\text{Ar}/^{39}\text{Ar}$ age of 35.08 ± 0.03 Ma (E.H. Christiansen, Brigham Young University, verbal communication, January 2010); locally consists of a breccia; also includes one exposure of dark-brown, densely welded, ash-flow tuff (vitrophyre) with a preliminary $^{40}\text{Ar}/^{39}\text{Ar}$ age of 35.21 ± 0.03 Ma (E.H. Christiansen, Brigham Young University, verbal communication, January 2010); unit includes one small exposure of rhyolitic tuff underlying Packard in Broad Canyon (Allen, in preparation); Morris and Lovering (1979) subdivided the Packard into several units that are not all present in the map area; exposed thickness to 500 feet (150 m).

TERTIARY-CRETACEOUS

TKb Siliceous breccia and breccia (Oligocene? to Eocene?, or Eocene? to Upper Cretaceous?) – Dark-brown silicified breccia in pods and fault-bounded blocks within Paleozoic sedimentary units in the Vernon Hills, possibly associated with Sevier orogenesis; alternately, the siliceous breccia may be related to regional volcanism during the Oligocene to Eocene; unit also includes small area of tan calcareous sandstone breccia near Highway 36; exposed thickness of roughly 300 feet (~100 m) (Kirby, 2010a, 2010b).

TKc Conglomerate (Eocene? to Upper Cretaceous?) – White, rusty-brown, and orange-red pebbly conglomerate, pebbly sandstone, and gritstone; clasts reflect local sources including quartzitic sandstone and black chert likely from Oquirrh Group and Paleozoic carbonates; medium- to crudely bedded and moderately to very resistant; present in western Traverse Mountains, South Willow Canyon of

Stansbury Mountains, and northern East Tintic Mountains; 0 to about 200 feet thick (0-60 m) (Biek and others, 2005; Copfer and Evans, 2005; Disbrow, 1961).

TKs **Tertiary-Cretaceous strata** (Eocene? to Upper Cretaceous?) – Interbedded conglomerate, limestone, mudstone, siltstone, and tuffaceous sandstone; red and red-brown conglomerate includes clasts of quartzite, carbonate, and sandstone in a sandy, gritty calcareous matrix; limestone is tan to pale-gray micrite that is medium bedded in intervals 10 to 20 feet (3-6 m) thick; mudstone and siltstone is red, red-brown, and purple with sandy lenses and is crudely to finely bedded; includes small exposure of breccia with Oquirrh fragments; likely Sevier synorogenic deposits that occur as folded strata along Highway 36 and adjacent to the Vernon Hills fault; radiometric age pending on ash bed; exposed thickness is greater than 2200 feet (>670 m) (Kirby, 2010a, 2010b).

DEVONIAN TO CAMBRIAN STRATA OF CAMELS BACK RIDGE AND SIMPSON BUTTES

We apply the regional stratigraphic names of Hintze and Robison (1975) and Hintze (1980) to Devonian through Cambrian strata of Camels Back Ridge rather than local names of the Dugway Range (Staatz and Carr, 1964; Staatz, 1972). Descriptions and thicknesses from Clark and others (2008); age data is contained within several sources (see Hintze and Davis, 2003, for a comprehensive treatment).

Dg? **Guilmette Formation?** (Upper to Middle Devonian) – Moderate- to dark-gray, thin- to thick-bedded, finely to moderately crystalline dolomite; locally weathers brownish gray, and forms ledges; exposed thickness about 500 feet (150 m).

Fault

Dsi **Simonson Dolomite** (Middle Devonian) – Light- to dark-gray, finely to moderately crystalline dolomite; locally weathers brownish gray; local zones of chert; thin- to very thick bedded unit forms cliffs and ledges; exposed thickness about 500 feet (150 m).

Dsy **Sevy Dolomite** (Lower Devonian) – Moderate-gray, finely crystalline dolomite that weathers light gray with laminated surface appearance; thin to medium bedded, forms ledges; thickness is about 250 feet (75 m).

Fault

Sl **Laketown Dolomite, undivided** (Silurian) – Moderate- to dark-gray, finely to moderately crystalline dolomite that locally weathers to light and moderate brown and light gray, and contains some intervals of light-gray dolomite; contains gray and red chert in beds, masses and nodules, and rust-colored, case-hardened surfaces; mostly very thick bedded, forming cliffs and ledges; to south separated

into several members (Hintze, 1980) corresponding to formations of Staatz and Carr (1964); exposed thickness is about 500 feet (150 m).

- Oes **Ely Springs Dolomite** (Upper Ordovician) – Includes upper part (Floride Member) and lower part (lower member) not mapped separately; upper part is very light gray, finely crystalline dolomite with indistinct to medium bedding; lower part is cherty, resistant, moderate-gray dolomite at top underlain by brown-weathering, less resistant, thin-bedded dolomite; both parts are thin to thick bedded, forming ledges, cliffs and slopes; thickness is 250 feet (75 m).

Unconformity – Tooele Arch (Hintze, 1959); Eureka Quartzite and uppermost part of Pogonip Group likely missing

- OCu **Lower Ordovician and Upper Cambrian strata, undivided** (Lower Ordovician? to Upper Cambrian?) – Carbonate rocks of Simpson Buttes; gray-, brown-, and pink-weathering dolomite and limestone, thin to very thick bedded; further subdivision precluded due to lack of access and exposure, but may correspond to parts of Pogonip Group, Notch Peak Formation, Orr Formation, and Lamb Dolomite; exposed thickness about 2300 feet (700 m).

- Op **Pogonip Group, undivided** (Middle to Lower Ordovician) – Exposed in low hills west of Camels Back Ridge; may include part of Kanosh Shale and underlying formations of this unit; upper part is dark-gray and moderate-gray, finely to moderately crystalline dolomite, underlain by moderate-gray intraformational conglomerate, siltstone, and limestone; thin to medium bedded, forming ledges and slopes; Hintze (1980) described the various formations; exposed thickness to 150 feet (45 m).

Fault – separating Camels Back Ridge from low hills to west

We have not applied the changes to the Ordovician-Cambrian boundary reported in Hintze and Kowallis (2009), considering the ongoing debate on this issue.

- OCn **Notch Peak Formation** (Lowermost Ordovician to Upper Cambrian) – Present on crest and west flank of Camels Back Ridge; moderate- and light-gray, finely to moderately crystalline dolomite and limey dolomite, containing intervals several feet thick that weather to tan and light pink; locally includes pisolites, twiggy bodies, and *Girvanella* (algae); medium to very thick bedded, cliff and ledge forming; Dugway Ridge Formation of Staatz and Carr (1964); exposed thickness about 500 feet (150 m).

- Cou **Orr Formation, upper part** (Upper Cambrian) – Present on east flank and crest of Camels Back Ridge; likely includes (descending order) Sneakover Limestone Member, Corset Spring Shale Member, Johns Wash Limestone Member, and Candland Shale Member; forms less resistant and lighter-colored interval between Notch Peak Formation and Big Horse Limestone; very light gray to light-gray,

finely to moderately crystalline dolomite and limestone, and green and light-brown shale; commonly medium to thick bedded; Fera Limestone of Staatz and Carr (1964); 200 feet (60 m) thick.

- Cob **Orr Formation, Big Horse Limestone Member** (Upper Cambrian) – Crops out on east flank and north part of Camels Back Ridge; medium- to very thick bedded, resistant interval forming cliffs and ledges; locally dolomitized; moderate-gray to tan-gray, finely to moderately crystalline limestone, with some intervals weathering to light tan, pink, and mottled; Straight Canyon Formation of Staatz and Carr (1964); 425 feet (130 m) thick.
- Cl **Lamb Dolomite** (Upper to Middle Cambrian) – Largely present on east flank of Camels Back Ridge; upper part less resistant, mostly very thin to thin bedded and commonly rusty and pink weathering, consists of ledges of moderate-gray oolitic and silty limestone and flat-pebble conglomerate, underlain by moderate-gray dolomite and limestone with rusty-colored blebs and layers; lower part of more resistant gray dolomite that locally weathers to mottled gray, pink gray, and light brown, is moderate to coarsely crystalline, and contains intervals of *Girvanella* (algae), thin- to very thick bedded interval forming ledges; 900 feet (275 m) thick.
- Ctl **Trippe Limestone** (Middle Cambrian) – Present on northeast side of Camels Back Ridge; forms generally less resistant and ledgy interval between Lamb Dolomite and Pierson Cove Formation; upper part is moderate-gray, laminated and nodular limestone, shale, intraformational conglomerate, and light-tan-weathering dolomite that is laminated to medium bedded; lower part is light- to moderate-gray, locally mottled, laminated to very thick bedded limestone; gradational contact with Pierson Cove Formation below; 700 feet (215 m) thick.
- Cpc **Pierson Cove Formation** (Middle Cambrian) – Present on northeast side of Camels Back Ridge; moderate-gray limestone with some light-gray dolomite interbeds, thin to very thick bedded forming ledges to cliffs; unit locally dolomitized; exposed thickness about 800 feet (245 m).

MISSISSIPPIAN STRATA OF LITTLE DAVIS MOUNTAIN

Descriptions and thicknesses from Clark and others (2008).

Onaqui fault

IPMmc

Manning Canyon Shale (Lower Pennsylvanian to Upper Mississippian) – See unit description under Oquirrh Mountains; exposed north and south of Little Davis Mountain; probably only lower part, about 200 feet (60 m), exposed.

Mgb **Great Blue Limestone** (Upper Mississippian) – Also see unit description under Oquirrh Mountains; medium- to dark-gray limestone and fossiliferous limestone, with black chert locally common as nodules and beds that are thin- to thick-bedded; southwestern exposures silicified; base and top? not exposed; exposed thickness is 1200 feet (370 m).

PERMIAN TO ORDOVICIAN STRATA OF SOUTHERN CEDAR MOUNTAINS AND SKULL VALLEY

Clark and others (2008) provided unit descriptions and their fossil age data are included in table 5. The Oquirrh Group has been substantially remapped to conform to the similar stratigraphy of the Oquirrh Mountains; refer to figure 3 for a comparison of Oquirrh strata between this map and Maurer (1970). The total thickness of Oquirrh Group strata is roughly 12,350 feet (3770 m). Following Laes and others (1997) and Hintze and Kowallis (2009), we combine Lower Permian (Wolfcampian) and Pennsylvanian formations under the Oquirrh Group, although this nomenclature differs from existing terminology established in the Oquirrh Mountains (Welsh and James, 1961; Tooker and Roberts, 1970).

PIPo **Oquirrh Group strata, undivided** (Lower Permian to Lower Pennsylvanian) – One area of combined unit on south margin of Cedar Mountains; exposed thickness about 50 feet (15 m).

PIPofm

Oquirrh Group, Freeman Peak, Curry Peak, and Bingham Mine Formations, undivided (Lower Permian and Upper Pennsylvanian, Wolfcampian-Virgilian) – One area along Cedar thrust, north of Rydalch Canyon.

Pofc **Oquirrh Group, Freeman Peak and Curry Peak Formations, undivided** (Lower Permian, Wolfcampian) – See unit description under Oquirrh Mountains; contains *Schwagerina* and *Triticites* cf. *T. meeki* (fusulinids); corresponds to most of Maurer's (1970) Unit 4 and Unit 5; 3500 feet (1070 m) thick.

Unconformity?

IPobm **Oquirrh Group, Bingham Mine Formation** (Upper Pennsylvanian, Virgilian-Missourian) – See unit description under Oquirrh Mountains; includes fusulinids (*Triticites* and *Pseudofusulinella*); corresponds to upper part of Maurer's (1970) Unit 3 and lower part of Unit 4; upper contact mapped at uppermost substantial limestone bed; 2800 feet (850 m) thick.

IPobw **Oquirrh Group, Butterfield Peaks Formation and West Canyon Limestone, undivided** (Middle to Lower Pennsylvanian, Desmoinesian-Morrowan) – Combined unit mapped in small exposures of southern Cedar Mountains.

IPobp **Oquirrh Group, Butterfield Peaks Formation** (Middle to Lower Pennsylvanian, Desmoinesian-Morrowan) – See unit description under Oquirrh Mountains; includes fusulinids (*Fusulina*, *Beedeina*); corresponds to Maurer’s (1970) Unit 2 and most of Unit 3; 5400 feet (1650) thick.

IPMwm

Oquirrh Group, West Canyon Limestone, and Manning Canyon Shale, undivided (Lower Pennsylvanian to Upper Mississippian, Morrowan-Chesterian) – Combined unit in small exposures of southern Cedar Mountains.

IPowc

Oquirrh Group, West Canyon Limestone (Lower Pennsylvanian, Morrowan) – See unit description under Oquirrh Mountains; corresponds to Maurer’s (1970) Unit 1; 500 to 800 feet (150-245 m) thick.

IPMmc

Manning Canyon Shale (Lower Pennsylvanian to Upper Mississippian, Morrowan-Chesterian) – See unit description under Oquirrh Mountains; probably 1500 to 2000 feet (450-600 m) thick.

Faults

Mgb **Great Blue Limestone** (Upper Mississippian) – See unit description under Oquirrh Mountains; no obvious shaley intervals; top not exposed; 2440+ feet (744+ m) thick.

Mh **Humbug Formation** (Upper Mississippian) – See unit description under Oquirrh Mountains; base not exposed; 1014+ feet (309+ m) thick.

Faults

Oes **Ely Springs Dolomite** (Upper Ordovician) – Dark- to medium-gray calcitic dolomite breccia (75% of exposures), light-gray silicic limestone breccia, and light-reddish-brown strongly recrystallized limestone with abundant reddish-brown chert, that is suggested as lower Fish Haven Dolomite (Geomatrix, 2001); exposures at Hickman Knolls on Skull Valley Indian Reservation; previously mapped by Moore and Sorensen (1979) as Ordovician carbonate rocks and quartzite; exposed thickness about 200 feet (60 m).

TRIASSIC TO CAMBRIAN STRATA OF SOUTHERN STANSBURY MOUNTAINS, VERNON HILLS, AND NORTHERN SHEEPROCK MOUNTAINS

Triassic to Permian stratigraphy of the Martin Fork syncline area was modified from Jordan and Allmendinger (1979).

- Trtw **Thaynes Limestone and Woodside Formation, undivided** (Lower Triassic) – *Thaynes* consists of light- to medium-gray and brown gastropod- and pelecypod-containing limestone, sandstone, and siltstone; the unit is resistant, bioturbated, and medium bedded (irregularly); regionally contains *Meekoceras* (ammonite) at base of unit (Kummel, 1954); underlying *Woodside* contains pale-red and brown siltstone and calcareous sandstone, greenish-brown shale, minor light-gray laminated limestone, that is poorly exposed and forms slopes; exposed thickness of *Thaynes* is 590 feet (180 m) and *Woodside* is 210 feet (65 m), and combined unit thickness is 800 feet (245 m).
- Ppfm **Park City Formation, Franson Member, and Phosphoria Formation, Meade Peak Phosphatic Shale Tounge, undivided** (Upper to Lower Permian) – *Franson* consists of moderate-brown and gray limestone and sandy limestone, calcareous sandstone that is medium bedded, with minor shale; *Meade Peak* consists of pale-red, brown, and dark-gray shale, with lesser bedded chert and phosphorite; forms a distinct red-brown-weathering slope or saddle; *Franson* is 280 feet (85 m) and *Meade Peak* is 230 feet (70 m) thick, and combined unit thickness is 510 feet (155 m).
- Ppg **Park City Formation, Grandeur Member** (Lower Permian) – Gray cherty and bioclastic limestone, sandy and cherty dolomite, calcareous sandstone, quartzite, and bedded chert; medium- to thick-bedded ledge former; thickness is 500 feet (150 m).
- Pdc **Diamond Creek Sandstone** (Lower Permian) – Moderate-gray, weathering to light-brown, fine-grained calcareous sandstone that is thin to medium bedded; thickness is about 350 feet (105 m).
- Pk **Kirkman Formation** (Lower Permian) – Moderate-gray to light-brown limestone, calcareous sandstone, fossiliferous carbonate conglomerate, and oncolitic limestone; limestone is locally bioclastic and cherty, and laminated with chert stringers and nodules; thin to thick bedded; exposed thickness is about 400 feet (120 m).

Martin Fork thrust fault – Oquirrh Group, Freeman Peak Formation omitted; Martins Fork Spring thrust (Tooker, 1983)

Oquirrh strata of the southern Stansbury Mountains were evaluated and described by Wright (1961), Armin (1979), Armin and Moore (1981), and Jordan (1979a, 1979b). New and existing fossil data is presented in table 5. It appears that both the upper (Freeman Peak Formation) and lower (West Canyon Limestone) parts of the Oquirrh Group have been truncated and omitted by faults near their respective contacts with enclosing units of regional decollement (Kirkman Formation above and Manning Canyon Shale below).

Pofc **Oquirrh Group, Freeman Peak and Curry Peak Formations** (Lower Permian, Wolfcampian) – See unit description under Oquirrh Mountains; maximum exposed thickness is about 3500 feet (1100 m).

Unconformity?

IPobm **Oquirrh Group, Bingham Mine Formation** (Upper Pennsylvanian, Virgilian-Missourian) – See unit description under Oquirrh Mountains; thickness is about 8000 feet (2450 m) in southern Stansbury Mountains and exposed thickness is about 1850 to 3200 feet (560-980 m) in Vernon Hills.

Fault in Vernon Hills

IPobp **Oquirrh Group, Butterfield Peaks Formation** (Middle to Lower Pennsylvanian, Desmoinesian-Morrowan) – See unit description under Oquirrh Mountains; exposed thickness to 6000 feet (1800 m) in southern Stansbury Mountains, and 1100 to 1250 feet (340-380 m) in Vernon Hills.

Broad Canyon and Big Hollow faults – West Canyon Limestone omitted in southern Stansbury Mountains. These faults have several names and interpretations: Broad Canyon fault (Rigby, 1958; Cashman, 1992), Broad Canyon thrust (Tooker and Roberts, 1971; Sorensen, 1982; Tooker, 1983), and Central Range fault (Copfer and Evans, 2005).

Fault in Vernon Hills

IPowc **Oquirrh Group, West Canyon Limestone** (Lower Pennsylvanian, Morrowan) – See unit description under Oquirrh Mountains; exposed thickness about 1150 to 1650 feet (350-500 m) in Vernon Hills.

IPMmc **Manning Canyon Shale** (Lower Pennsylvanian to Upper Mississippian, Morrowan-Chesterian) – See unit description under Oquirrh Mountains; exposed thickness 0 to 1300 feet (0-400 m).

Fault in Vernon Hills

Mgb **Great Blue Limestone, undivided** (Upper Mississippian) – See unit description under Oquirrh Mountains; mapped as combined unit in the Vickory Mountain and Deadman anticline areas where the Long Trail Shale is not well exposed or absent; thickness about 1600 feet (490 m).

Mgbu **Great Blue Limestone, upper limestone member** (Upper Mississippian) – See unit description under Oquirrh Mountains; thickness is 800 feet (240 m).

Mgbs **Great Blue Limestone, Long Trail Shale Member** (Upper Mississippian) – See unit description under Oquirrh Mountains; thickness is 30 to 80 feet (10-25 m).

Mgbl **Great Blue Limestone, lower limestone member** (Upper Mississippian) – See unit description under Oquirrh Mountains; thickness is 700 feet (210 m) in southern Stansbury Mountains and incomplete thickness is 440 to 820 feet (130-250 m) in Vernon Hills.

Mh **Humbug Formation** (Upper Mississippian) – See unit description under Oquirrh Mountains; thickness is 700 feet (210 m) in southern Stansbury Mountains, and 850 to 1250 feet (260-380 m) in Vernon Hills.

Fault in Vernon Hills

Md **Deseret Limestone** (Upper to Lower Mississippian) – See unit description under Oquirrh Mountains; thickness is 525 feet (160 m) in southern Stansbury Mountains and attenuated thickness is about 200 feet (60 m) in Vernon Hills.

MDgs **Gardison Limestone, Fitchville Formation, Pinyon Peak Limestone, Stansbury Formation, undivided** (Lower Mississippian to Upper Devonian) – Combined unit north of head of Dry Canyon in southern Stansbury Mountains; see individual unit descriptions below; Stansbury Formation thins northward to zero near head of Indian Hickman Canyon, and northward the Pinyon Peak and Fitchville are cut out by the unconformity; thickness is about 1200 feet (370 m).

Mg **Gardison Limestone** (Lower Mississippian) – See unit description under Oquirrh Mountains; thickness is 700 feet (210 m) in southern Stansbury Mountains and 840 feet (260 m) in Vernon Hills.

Unconformity

MDfs **Fitchville Formation, Pinyon Peak Limestone, Stansbury Formation, undivided** (Lower Mississippian to Upper Devonian) – Combined unit south of Dry Canyon head; refer to Fitchville-Pinyon Peak description below; Stansbury Formation is distinctive carbonate-clast conglomerate with rounded and commonly oblate light- and dark-gray carbonate clasts from 0.5 to 4 inches (1-10 cm) in diameter in a tan sandy dolomite matrix; Fitchville-Pinyon Peak thickness is about 450 feet (140 m), Stansbury thickness is about 0 to 60 feet (0-20 m), and combined unit thickness is about 500 feet (150 m).

MDfp **Fitchville Formation and Pinyon Peak Limestone, undivided** (Lower Mississippian to Upper Devonian) – Gray, medium-bedded limestone (Fitchville) overlying gray to tan sandy and silty limestone that is locally bioclastic and irregularly bedded (Pinyon Peak); thickness is about 200 feet (60 m) in southern Stansbury Mountains and 60 feet (20 m) in Vernon Hills.

Dst **Stansbury Formation** (Upper Devonian) – White quartzite that weathers to tan and pale red, is locally cross-bedded, thin to medium bedded; exposed in quarry and adjacent hills southeast of Box Elder Canyon, Stansbury Mountains; exposed thickness is 200 feet (60 m) in Stansbury Mountains, but is absent to south and east.

Major unconformity – Stansbury uplift (Rigby, 1959a; Morris and Lovering, 1961)

Descriptions and thicknesses for Devonian through Cambrian units from Kirby (2010a, b) and this study. Also refer to Hintze and Davis (2003) for age data.

DOu **Guilmette Formation, Simonson, Sevy, Laketown, and Ely Springs Dolomites, undivided** (Upper Devonian to Upper Ordovician) – Combined unit in the southern Stansbury Mountains where subdivision is not complete; *Guilmette* includes dark-gray, well bedded limestone; *Simonson* is dark-gray, coarsely to medium crystalline dolomite; *Sevy* is very light gray, finely crystalline dolomite; *Laketown* is gray, medium- to thick-bedded, coarsely to medium crystalline dolomite; *Ely Springs* is dark-gray and mottled, medium crystalline dolomite; Guilmette newly recognized and Ely Springs previously mapped as the Fish Haven Dolomite; thickness is 0 to about 2000 feet (600 m).

Dg **Guilmette Formation** (Upper to Middle Devonian) – Dark-gray, medium- to fine-grained, moderately to weakly bedded, sparsely fossiliferous dark-gray dolomite with a few thin, dark-gray, fine-grained limestone beds near the top of unit; forms slopes and ledges; 180 feet (50 m) thick in Vernon Hills.

Dsi **Simonson Dolomite** (Middle Devonian) – Light-brownish to pale- and medium-gray, fine to medium-grained, very thick or thin-bedded dolomite; generally more lithologically variable and less well bedded than the underlying Sevy; 570 to 890 feet (170-270 m) thick in Vernon Hills.

Dsy **Sevy Dolomite** (Lower Devonian) – White to very-light or medium-gray, medium- to fine-grained dolomite; displays well developed fine-scale planar lamination on surface; rarely fossiliferous; contains uncommon thin beds of sandy dolomite; forms ledges and float-covered hills; 710 to 830 feet (220-250 m) thick in Vernon Hills.

Unconformity

SOu **Laketown and Ely Springs Dolomites, undivided** (Silurian and Upper Ordovician) – Dark- to medium-gray, granular to fine grained, moderately or poorly bedded cherty dolomite; common pink to dark-gray chert bands or nodules; fossils include rugose corals and rare stromatolites in lower part of unit and chain corals near upper contact; poorly bedded parts of this unit appear bioturbated; forms small blocky outcrops and steep slopes; exposed thickness is 1060 to 1280 feet (320-390 m) in Vernon Hills.

Oe **Eureka Quartzite** (Upper Ordovician) – Light-colored, medium- to well-bedded, medium-grained, vitreous orthoquartzite; commonly displays well-developed trough cross-bedding and planar bedding; unit crops out as small blocky cliff bands less than 10 feet (3 m) high at two locations in southern Vernon Hills; exposed thickness is 40 to 80 feet (12-24 m), but absent in the southern Stansbury Mountains.

Unconformity – Tooele Arch (Hintze, 1959); Eureka Quartzite locally missing

Op **Pogonip Group, undivided** (Middle to Lower Ordovician) –Blue-gray-weathering limestone and reddish-tan-weathering silty limestone with lesser intraformational conglomerate and minor shale; thin to medium bedded in ledgy exposures; upper part is about 100 feet (30 m) of slope-forming black to dark-brown shale and lesser siltstone and sandstone (Kanosh Shale); previously mapped as Kanosh Shale and Garden City Formation (Rigby, 1958; Teichert, 1958); thickness is 0 to 1350 feet (410 m) in southern Stansbury Mountains.

Clark and Kirby (2009) reevaluated the Cambrian stratigraphy of the Stansbury and northern Sheeprock Mountains. These strata closely resemble the western Utah section (Hintze and Robison, 1975) rather than the East Tintic Mountains section as initially applied by Rigby (1958) and perpetuated by Sorensen (1982) and Copfer and Evans (2005). Our revised terminology includes the following units (descending order): Notch Peak Formation; Orr Formation, upper part, includes Sneakover Limestone Member, Corset Spring Shale Member, and Johns Wash Limestone Member?; Orr Formation, Big Horse Limestone Member; Lamb Dolomite; Trippe Limestone (Fish Springs Member and lower member); Pierson Cove Formation; Wheeler Formation; Swasey Limestone; Whirlwind Formation; Dome Limestone; Chisholm Formation; Howell Limestone; Pioche Formation; Prospect Mountain Quartzite (figure 4). Locally some of these units are combined on the map where thin or where mapping is incomplete.

Cum **Upper and Middle Cambrian strata, undivided** (Upper and Middle Cambrian) – Combined unit of several formations in the southern Stansbury Mountains where subdivision is not fully complete; includes carbonates and shales of the Notch Peak, Orr, Lamb, Trippe, Pierson Cove, Wheeler, Swasey, Whirlwind, Dome, Chisholm, and Howell formations; northward, the upper part of the section was removed by erosion associated with the Stansbury uplift; thickness roughly 1500 to 5000 feet (450-1500 m).

Cmu **Middle Cambrian strata, undivided** (Middle Cambrian) – Several carbonate and shale rock units composing the upper plate of a low-angle normal fault on the southwest margin of the Stansbury Mountains; may include the lower Trippe, Pierson Cove, Wheeler, and Swasey formations; thickness roughly 1500 feet (450 m).

- Cws **Wheeler Formation and Swasey Limestone, undivided** (Middle Cambrian) – *Wheeler* is red-brown to medium- or dark-gray, thin- to medium-bedded calcareous shale and limestone that generally forms slopes; contains *Peronopsis* trilobite fauna (Hintze and Davis, 2003); *Swasey* is medium-gray, medium- to thin-bedded, blocky, cliff- and ledge-forming limestone; includes sections of silty, ribbon limestone and wackestone; contains *Elrathia* trilobite fauna (Hintze and Davis, 2003); exposed thickness of combined unit about 720 feet (220 m).
- Cwh **Whirlwind Formation, Dome Limestone, Chisholm Formation, Howell Limestone, undivided** (Middle Cambrian) – *Whirlwind* is light-olive-gray to red or brown shale and argillite interbedded with thin-bedded limestone; contains *Ehmaniella* trilobite fauna (Hintze and Davis, 2003); *Dome* is medium-gray, medium- to thin-bedded, blocky limestone that forms ledges; *Chisholm* is brown to red-brown shale and some dark-gray pisolitic limestone, and contains *Glossopleura* trilobite fauna (Hintze and Davis, 2003); *Howell* is light- to dark-gray limestone that forms ledges; combined unit thickness is 880 feet (360 m).
- Cp **Pioche Formation** (Middle and Lower Cambrian) –Red-brown and green-brown shale and phyllitic shale with interbedded quartzite; upper part contains red-brown limestone that is irregularly bedded and some gray limestone and shale; thin to medium bedded unit forms ledges and some slopes; thickness is about 300 feet (90 m) or less.
- Cpm **Prospect Mountain Quartzite** (Lower Cambrian) –Light-gray to very light gray, commonly reddish-brown-weathering quartzite that is thin to thick bedded and medium to coarse grained; uppermost part is reddish-brown, medium- to thick-bedded, pebbly quartzite; lowermost part is light-pink, brown, and maroon quartzite conglomerate and is lithologically similar to the underlying and unexposed Mutual Formation; exposed in core of the Deseret anticline along crest of Stansbury Mountains; approximately 4200 feet (1280 m) exposed; complete thickness regionally is 2800 to 5700 feet (850-1740 m) (Hintze and Kowallis, 2009).

PERMIAN TO CAMBRIAN STRATA OF SOUTHERN OQUIRRH MOUNTAINS, SOUTH MOUNTAIN, AND WESTERN TRAVERSE MOUNTAINS

The Permian-Pennsylvanian rocks of the southern Oquirrh Mountains are considered part of the Bingham Sequence, present south of the North Oquirrh thrust fault (Tooker and Roberts, 1970). Considering regional relations, and similar to Laes and others (1997) and Hintze and Kowallis (2009), we combine Lower Permian (Wolfcampian) and Pennsylvanian formations under the Oquirrh Group; this nomenclature differs from existing terminology established in the Oquirrh Mountains (Welsh and James, 1961; Tooker and Roberts, 1970), which restricted the Oquirrh Group to strata of Pennsylvanian age. Oquirrh Group strata of the southern Oquirrh Mountains totals nearly 20,000 feet (6100 m) (Tooker and Roberts, 1970; Swenson, 1975), while equivalent strata in the

Wasatch Range totals up to approximately 29,000 feet (8850 m) (Constenius and others, 2010). Regarding the South Mountain-Stockton area, relations indicate these rocks are in a different thrust plate than the southern Oquirrh Mountains, but we disagree with Tooker and Roberts' separate terminology of formational units (South Peak, Salvation, and Rush Lake) that constitute the Oquirrh Group rocks in their South Mountain nappe (Tooker and Roberts, 1988; Tooker and Roberts, 1992; Tooker and Roberts, 1998; Tooker, 1999); instead, we use nomenclature of the Bingham Sequence. We also revised the mapping and stratigraphic interpretations of Welsh and James (1998) on South Mountain. New fossil data are provided in table 5. Unit descriptions and ages for the Permian-Pennsylvanian-Mississippian strata are from Welsh and James (1961), Tooker and Roberts (1970), Swenson (1975), Jordan (1979a, 1979b), Tooker (1987), Biek (2004), Biek and others (2005), and this study.

Thrust fault

Pdk Diamond Creek Sandstone and Kirkman Formation, undivided (Lower Permian, Leonardian? to Wolfcampian) – Gray to tan, weathering to red-brown, fine-grained sandstone and quartzite that is thin to medium bedded; slope-forming unit weathers to chips and blocks; the Kirkman is atypical and may be represented by a 30-foot-thick (10 m) sandy limestone at base of unit and some overlying sandstone (Welsh and James, 1998) or may be attenuated; limited age data; top not exposed, incomplete thickness is 2600 feet (790 m) in South Mountain.

In the central Oquirrh Mountains (north of map area), this unit is located beneath the North Oquirrh thrust and consists of discontinuous beds and slump blocks of limestone and sandstone commonly contorted with intraformational breccia roughly 2000 feet (600 m) thick (Tooker and Roberts, 1970; Swenson, 1975; Laes and others, 1997). In the Wasatch Range, Constenius demonstrated that the Kirkman is a weak, intensely deformed interval, similar to the Manning Canyon Shale (Constenius and others, 2010).

Pofp Oquirrh Group, Freeman Peak Formation (Lower Permian, Wolfcampian) – Light-brown, weathering to red-brown, fine-grained sandstone and quartzite; medium to thick bedded, resistant and jointed forming blocky ledges and talus-covered slopes; thickness is 2900 feet (880 m) in South Mountain; 2400 feet (730 m) thick on Freeman Peak in Bingham district (Swenson, 1975).

Pocp Oquirrh Group, Curry Peak Formation (Lower Permian, Wolfcampian) – Dark-gray, weathering to light gray and tan, very fine grained calcareous sandstone and siltstone that is poorly bedded (thin), and includes some minor quartzite and limestone intervals; sparsely fossiliferous, but worm tracks and trails are abundant on bedding planes; quartzite lacks fine banding; forms chippy slopes with few ledges; thickness is 1800 feet (550 m) in South Mountain; 2450 feet (750 m) thick in reference section on Curry Peak in Bingham district (Swenson, 1975).

Unconformity?

IPo **Oquirrh Group, Bingham Mine and Butterfield Peaks Formations, undivided** (Upper to Lower Pennsylvanian) – Combined unit in small exposures of western Traverse Mountains and southern Oquirrh Mountains.

Tooker and Roberts (1970, 1998) separated the Bingham Mine Formation into the Markham Peak and Clipper Ridge Members based on lithology. Swenson (1975, p. 28) did not consider the type locality of the Markham Peak Member to represent a valid section and instead informally referred to these two divisions as the upper and lower members following Welsh and James (1961). Although subsequent Kennecott maps largely followed Swenson's mapping, they used the names Markham and Clipper Members for the upper and lower parts (Swenson and Kennecott, 1991; Laes and others, 1997). We use Swenson's informal two-member terminology only in the vicinity of Bingham mine.

IPobm **Oquirrh Group, Bingham Mine Formation, undivided** (Upper Pennsylvanian, Virgilian-Missourian) – Brown-weathering, fine-grained quartzitic sandstone, quartzite, and calcareous sandstone with interbeds of medium- to dark-gray, fine-grained sandy and cherty limestone; light-brown to pale-red sandstones are very fine grained, feldspathic, and cross-laminated; limestone can be poorly bedded; overall sandstone predominates over limestone; forms talus-covered slopes with some intervening ledges; thickness is 5300 to 6500 feet (1600-2000 m) in Bingham district (Welsh and James, 1961; Swenson, 1975) and 6375 feet (1940 m) in South Mountain (Welsh and James, 1998).

IPobmu

Oquirrh Group, Bingham Mine Formation, upper member (Upper Pennsylvanian, Virgilian?) – Light-gray to brownish-tan, thin-banded, and locally cross-bedded calcareous quartzite with interbedded thin, light- to medium-gray, calcareous, fine-grained sandstone, limestone, and siltstone; several of the thin calcareous units are locally important as marker beds; unit is very similar to the lower member above the Commercial Limestone; 2200 feet (670 m) thick in the Oquirrh Mountains (Swenson, 1975).

IPobml

Oquirrh Group, Bingham Mine Formation, lower member (Upper Pennsylvanian, Missourian) – Unit includes the Commercial and basal Jordan Limestone marker beds (important Bingham ore hosts); most of the unit consists of light-gray to brownish-tan, banded orthoquartzite and calcareous quartzite with thin, interbedded, light- to medium-gray, calcareous, fine-grained sandstone, limestone, siltstone, and minor shale; the Commercial consists of thin-bedded, dark-gray to black, argillaceous, silty and cherty limestone, while the Jordan is thin-bedded, dark-gray, argillaceous and silty, cherty limestone and arenaceous limestone; Missourian-age conodont fauna were recovered from the Jordan Limestone east of Tooele (S.R. Ritter, Brigham Young University, written

communication, October 27, 2009); thickness is about 3100 feet (945 m) near Middle Canyon (Swenson, 1975).

The Butterfield Peaks Formation was divided into upper and lower parts on Laes and others' (1997) map after Swenson (1975, p. 26). The upper part corresponds to the sandier upper portion of Swenson, while the lower part corresponds to Swenson's middle and lower parts, which contain more limestone. Swenson and Kennecott's (1991) map did not include this separation, and we do not find it useful regionally.

IPobp Oquirrh Group, Butterfield Peaks Formation (Middle to Lower Pennsylvanian, Desmoinesian-Morrowan) – Generally characterized by cyclically interbedded limestone and clastic intervals; limestone is medium gray and locally fossiliferous, arenaceous, cherty, and argillaceous in thin to thick beds; limestone contains locally abundant brachiopod, bryozoan, coral, and fusulinid fauna; diagnostic black chert weathers brown and locally occurs as spherical nodules and laterally linked masses; light-brown calcareous quartzite, orthoquartzite, and calcareous sandstone is thin to medium bedded and locally cross-bedded; includes some poorly exposed light-gray siltstone and mudstone interbeds; overall limestone predominates over quartzite and sandstone, with clastic percentages increasing upsection; unit forms ledges and cliffs with regularly intervening slopes; thickness is 9000 feet (2765 m) on Butterfield Peaks (Tooker and Roberts, 1970).

IPowc Oquirrh Group, West Canyon Limestone (Lower Pennsylvanian, Morrowan) – Medium-gray limestone, sandy limestone, and fossiliferous limestone that is thin to medium bedded; locally laminated with silt and sand, some sparse chert; locally includes minor thin sandstone and quartzite in middle and near contacts; fossils include crinoid columnals, brachiopods, bryozoans, rugose corals, and fusulinids; forms ledgy exposures; forms basal carbonate package of Oquirrh Group; thickness from 1053 to 1456 feet (321-444 m) at reference and type sections (Nygreen, 1958; Tooker and Roberts, 1970).

IPMmc

Manning Canyon Shale (Lower Pennsylvanian to Upper Mississippian, Morrowan to Chesterian) – Lithologically diverse unit of predominantly shale with lesser sandstone, quartzite, and limestone; black to grayish purple calcareous and carbonaceous shale and siltstone; light brown, fine-grained calcareous sandstone with cross-bedding; brown-weathering, medium- to thick-bedded orthoquartzite with vitreous luster; medium-gray to bluish-gray fossiliferous and argillaceous limestone, thin to thick bedded; fossils include brachiopods, bryozoans, rare trilobites, and leaves; weak, slope-forming unit; conodont age data in Soldier Canyon from Webster and others (1984), and palynomorphs there (C. Morgan, UGS, verbal communication, April 13, 2009) suggest a middle to late Chesterian age; interval of regional decollement, commonly exhibiting substantial deformation; Soldier Canyon in the Oquirrh Mountains contains one of the few, relatively intact sections, although some internal disturbance is noted;

thickness at Soldier Canyon is 1140 feet (347 m) (Gilluly, 1932) to 1559 feet (475 m) (Moyle, 1959).

- Mgbus **Great Blue Limestone, upper limestone and shale member** (Upper Mississippian) – Interbedded banded, silty and arenaceous, blue-gray, medium-bedded, sparsely fossiliferous limestone and thick section of fissile, greenish-black shale and interbedded thin chert and quartzite lenses; source of brick clay deposits and local variscite deposits; unit is a different facies of the upper limestone member with more shale at south end of the Oquirrh Mountains near Fivemile Pass, which Tooker (1999) called a separate structural block, whereas Laes and others (1997) mapped it as an upper shale unit within their upper limestone unit; exposed thickness is roughly 2000 feet (610 m).
- Mgbu **Great Blue Limestone, upper limestone member** (Upper Mississippian) – Limestone, cherty and argillaceous limestone, and calcareous shale; sparsely fossiliferous and thin to medium bedded forming ledges, cliffs, and slopes; also informally called Mercur limestone member (Gordon and others, 2000); unit grades laterally southward into Mgbus near Fivemile Pass; Great Blue age data from Gordon and others (2000); thickness of upper limestone member is 1545 feet (470 m), and possibly thicker per Gilluly (1932).
- Mgbs **Great Blue Limestone, Long Trail Shale Member** (Upper Mississippian) – Black to dark-green calcareous and carbonaceous shale in upper part, fossiliferous argillaceous limestone and silty limestone in lower part; thin-bedded, slope-forming interval between enclosing limestones; maximum thickness is 110 feet (33 m).
- Mgbl **Great Blue Limestone, lower limestone member** (Upper Mississippian) – Blue-gray limestone and argillaceous limestone, interbedded with calcareous sandstone and sandy limestone; thin to medium bedded, locally silicified (jasperoid of Laes and others, 1997), and locally fossiliferous (brachiopods, corals, bryozoans), forming ledges, slopes, and cliffs; also informally called Silveropolis limestone member (Gordon and others, 2000); upper part of lower limestone member (mineralized interval) was called the Mercur series (Laes and others, 1997) and Mercur member (Mako, 1999); thickness is 500 to 850 feet (150-260 m).
- Mh **Humbug Formation** (Upper Mississippian) – See unit description under northern East Tintic Mountains; thickness is 650 feet (200 m).
- Md **Deseret Limestone** (Upper to Lower Mississippian) – See unit description under northern East Tintic Mountains; thickness is 650 feet (200 m).
- Mg **Gardison Limestone** (Lower Mississippian) – See unit description under northern East Tintic Mountains; thickness is 460 feet (140 m).

Unconformity

MDfp **Fitchville Formation and Pinyon Peak Limestone, undivided** (Lower Mississippian and Upper Devonian) – Also see unit description under northern East Tintic Mountains; gray, coarsely crystalline dolomite that weathers dark gray; within upper cliffy part of unit is one massive bed that contains conspicuous white calcite fossil casts up to a few inches in diameter, called the “eye bed” (Gilluly, 1932); some thin limestone and sandstone beds are present in slope below this bed; forms prominent cliff and slope in Dry and Ophir Canyons of the Oquirrh Mountains; Gilluly (1932) originally mapped as Jefferson(?) dolomite and Tooker (1987) subsequently used Fitchville-Pinyon Peak; thickness is 185 feet (56 m).

Unconformity

Cambrian rock units are only exposed in the core of the Ophir anticline of the southwestern Oquirrh Mountains. Gilluly (1932) noted the lithologic similarities of Cambrian units in the Oquirrh Mountains to the East Tintic Mountains area, but was unsure of direct correlations and thus applied local names that were subsequently adopted by Tooker (1987, 1999), although not formalized in USGS Geologic Names Lexicon. Rigby (1959b) used East Tintic terminology for the Cambrian rock units in the Oquirrh Mountains, which were also used on Laes and others (1997) map. We conclude that although there are similarities to the East Tintic section, the lithofacies present warrant use of the local names of Gilluly (1932). Descriptions and thickness data from Gilluly (1932).

- Cly **Lynch Dolomite** (Upper? to Middle? Cambrian) – Light-gray dolomite with a few limestone beds in lower half; lower part also includes dark-gray dolomite containing twiggy bodies (short white carbonate rods); thick-bedded, prominent cliff-forming unit in Ophir Canyon; may correlate with Opex Formation? and Cole Canyon and Bluebird Dolomites in the East Tintics (Gilluly, 1932; Morris and Lovering, 1961); thickness from 825 to 1050 feet (250-320 m).
- Cb **Bowman Limestone** (Middle? Cambrian) – Mottled shaley limestone, intraformational conglomerate, and oolitic limestone; includes a shaley/hornfels unit about 40 feet (12 m) thick at base; sparse trilobite fauna; may correlate with upper part of Herkimer Limestone in East Tintics (Gilluly, 1932; Morris and Lovering, 1961); thickness is 280 feet (85 m).
- Ch **Hartmann Limestone** (Middle? Cambrian) – Banded gray, mottled, thin-bedded, silty and shaley limestone; oolitic toward the top, and containing sparse trilobite fauna; may correlate to the lower part of Herkimer Limestone and Teutonic Limestone in East Tintics (Gilluly, 1932; Morris and Lovering, 1961); thickness is 655 feet (200 m).
- Cop **Ophir Formation** (Middle Cambrian) – Gray shale and micaceous shale, with several beds of mottled shaley limestone in middle of unit, and sandy shale and

quartzite near base; brachiopod and trilobite (*Olenellus*) fauna; thickness is 320 feet (98 m).

- Ct **Tintic Quartzite** (Middle? to Lower? Cambrian) – White quartzite that weathers to reddish brown; bedding is thick and locally irregular and cross-bedded; only upper part exposed in core of Ophir anticline, where it becomes increasingly shaley and grades into the overlying Ophir Formation; exposed thickness to 300 feet (90 m).

PENNSYLVANIAN TO NEOPROTEROZOIC STRATA OF THORPE HILLS AND NORTHERN EAST TINTIC MOUNTAINS

Unit descriptions, age and thickness data from Disbrow (1957, 1961) and Morris and Lovering (1961), in part modified from the work of Lindgren and Loughlin (1919).

- IPobp **Oquirrh Group, Butterfield Peaks Formation** (Middle to Lower Pennsylvanian, Desmoinesian-Morrowan) – See unit description under Oquirrh Mountains; corresponds to Disbrow's (1957, 1961) Oquirrh formation units 2 through 5; Desmoinesian conodont age from Ten Mile Hill (McKean and others, in preparation); incomplete thickness is about 3650 feet (1110 m).

- IPowc **Oquirrh Group, West Canyon Limestone** (Lower Pennsylvanian, Morrowan) – See unit description under Oquirrh Mountains; corresponds to Disbrow's (1957, 1961) Oquirrh formation unit 1; about 750 feet (230 m) thick.

IPMmc

Manning Canyon Shale (Lower Pennsylvanian to Upper Mississippian, Morrowan to Chesterian) – See unit description under Oquirrh Mountains; medial limestone interval about 30 to 80 feet (10-25 m) thick; unit thickness is 1050 feet (320 m).

Tenmile Pass fault

The typical stratigraphy of the Great Blue changes near the south end of the Oquirrh Mountains. Southward, Disbrow (1957, 1961) and Morris and Lovering (1961) used a different stratigraphic nomenclature in the northern East Tintic Mountains. Further evaluation of these stratigraphic changes is warranted.

- Mgbk **Great Blue Formation, Poker Knoll Limestone Member** (Upper Mississippian) – Upper member of dark- to light-gray and tan limestone that is medium to fine grained and thin bedded, weathering to platy chips; includes much interlayered brown-weathering black chert 1 to 12 inches (2.5-3 cm) thick and also in elongated nodules; locally includes thin beds of black and brown shale; no good complete section exposed; about 600 feet (180 m) thick.

- Mgbc **Great Blue Formation, Chiulos Shale Member** (Upper Mississippian) – Medial member consisting largely of shale with lesser quartzite and minor limestone; the olive-green and black shale forms slopes; the upper half has more quartzite that is pale-olive-green, brown, maroon, pink, and white in color, with beds that vary considerably in thickness and extent, and are fine to medium grained and cross-bedded; the lower half is largely shale with some thin beds of quartzite that is brown weathering, medium grained, and cross-bedded in middle and upper parts, and uncommon lenses of medium-grained, blue-gray weathering limestone in lower part; unit is lithologically similar to the Manning Canyon Shale; about 850 feet (260 m) thick.
- Mgbp **Great Blue Formation, Paymaster Member and Topliff Limestone Member, undivided** (Upper Mississippian) – Lower member generally of blue-gray limestone with chert and two zones of olive shale and quartzite in upper half that Disbrow mapped as a combined unit; *Paymaster* is mostly limestone with some interbedded brown-weathering olive-green shale and quartzite; limestone is blue- and medium-gray to tan, fine- to medium grained, commonly streaked with tan- and red-weathering silt and clay; chert is common as nodules, pods and thin layers; Paymaster thickness is 620 feet (190 m); *Topliff* is blue-gray and medium-gray limestone, fine to medium grained, distinctly bedded from thin to thick, locally with uncommon nodules of black and brown chert; fossils are locally abundant (crinoids, horn corals, bryozoans, brachiopods); Topliff thickness is 460 feet (140 m); combined unit thickness is 1080 feet (330 m).
- Mh **Humbug Formation** (Upper Mississippian) – Interbedded calcareous quartz sandstone, orthoquartzite, and limestone that weather to ledgy slopes; limestone is medium to dark gray, medium to very thick bedded with uncommon brachiopod, coral and bryozoa fauna; locally contains some light-gray sublithographic limestone in uppermost part; sandstone and quartzite is brown weathering and commonly lenticular, medium to very thick bedded, locally cross-bedded; in isolated exposures can be confused for Oquirrh Group strata; about 600 feet (180 m) thick.
- Md **Deseret Limestone** (Upper to Lower Mississippian) – Blue-gray limestone that is medium to very thick bedded and locally sandy, fossiliferous, and cherty, forming ledges and cliffs; basal part contains slope-forming black shale and chert (red weathering) of the Delle Phosphatic Shale Member (0 to 30 feet [10 m] thick) (also see Sandberg and Gutschick, 1984); in the Tintic mining district, Morris and Lovering (1961) subdivided the Deseret above the Delle into the Tetro member and Uncle Joe member based on lithology, but we did not map these members separately; thickness is about 700 feet (215 m).
- Mg **Gardison Limestone** (Lower Mississippian) – Medium- to dark-gray limestone and cherty limestone that is very fossiliferous and well bedded; upper part is thicker bedded (medium to very thick), sandy and cherty, forming cliffs and ledges, while lower part is thinner bedded (thin and medium) and less resistant

forming ledges and slopes; black chert occurs as nodules and thin beds; fossils include rugose and colonial corals, brachiopods, gastropods, and bryozoans, some fossils are replaced by white calcite; 450 feet (140 m) thick.

Unconformity

MDf Fitchville Formation (Lower Mississippian and Upper Devonian) – Commonly divided into three parts; upper part consists of very thick bedded pink sublithographic limestone capped by a 3-foot (1-m) or less bed of laminated light- and dark-gray stromatolitic limestone (the “Curley” limestone, see Proctor and Clark, 1956); middle part is black dolomite or limestone with scattered pods of chert or coarsely crystalline white dolomite; lower part is light- to medium-gray shaly limestone; fossils include corals and brachiopods; forms cliffs and ledges; thickness about 300 feet (90 m).

Dpv Pinyon Peak Limestone and Victoria Formation, undivided (Upper Devonian) – *Pinyon Peak* is thin- and very thick-bedded, medium-gray to light blue-gray limestone; sandy at the top and containing a brown sandstone and a tan shaly limestone unit near the base; fossils include crinoids, brachiopods and bryozoans; 125 to 175 feet (40-55 m) thick; separated by a probable unconformity from the underlying Victoria Formation; *Victoria* is medium- to light-gray dolomite that is fine to medium grained with a minor amount of light-brown, rusty weathering quartzite and quartzite breccia; locally a 4-foot-thick (1 m) bed of dark-gray dolomite crowded with ¼-inch white dolomite crystals is present a few feet above base of formation; Victoria is 125 feet (40 m) thick; slope and ledge forming unit; combined unit thickness is 250 to 300 feet (75-90 m).

Unconformity

DOb Bluebell Dolomite (Upper Devonian to Upper Ordovician) – Light- and dark-gray dolomite, thick and thin bedded, generally banded and mottled in appearance, locally cherty at base and sandy near top; sparsely fossiliferous with crinoids, corals, and pentamerid brachiopods; locally distinctive 10-foot-thick (3 m) bed of laminated light- and dark-gray dolomite in middle of formation (Colorado Chief marker bed); ledge former; contains two unconformities (Budge and Sheehan, 1980); thickness is about 600 feet (180 m).

Of Fish Haven Dolomite (Upper Ordovician) – Medium- and light-gray dolomite in very thick and thin beds that weather to a rough surface texture; nodular chert-bearing and mottled beds common in upper 1/3 of formation; fossils include crinoids, corals, brachiopods; distinctive mottled dolomite, the Leopard Skin marker bed (50 to 100 feet [15-30 m] thick) is at top of formation; forms cliffs and slopes; Fish Haven is 270 feet (80 m) thick.

Unconformity

Oo **Opohonga Limestone** (Lower Ordovician) – Distinctive unit of light-blue-gray, thin-bedded limestone with seams and beds of yellow, pink and red mudstone that give a striped, mottled or mosaic appearance; flat-pebble conglomerate beds common throughout; pods of white chert typical in lower 1/3 of formation; basal beds are brown sandstone; slope forming unit with flaggy outcrops; thickness is about 800 feet (245 m).

We have not applied the changes to the Ordovician-Cambrian boundary reported in Hintze and Kowallis (2009), considering the ongoing debate on this issue.

Cao **Ajax Dolomite and Opex Formation, undivided** (Lowermost Ordovician to Upper Cambrian) – *Ajax* is light- to dark-blue-gray, cherty dolomite with a medial interval of creamy white dolomite (Emerald Member) that is 15 to 30 feet (5-10 m) thick; chert is less common in lower part; well bedded (thin to thick) forming cliffs and ledges; Ajax thickness is 600 feet (180 m); *Opex* is light- and dark-gray limestone mottled and streaked with yellow and red mudstone; thin beds of sand-streaked limestone and flat-pebble conglomerate interlayered throughout; 10 feet (3 m) of greenish-gray shale near top and light-gray oolitic dolomite 40 to 70 feet (12-20 m) thick near base; thin bedded and forms slopes; Opex thickness is 250 feet (75 m); combined unit thickness is 850 feet (260 m).

Cc **Cole Canyon Dolomite** (Middle Cambrian) – Upper part (about 625 feet [190 m]) of alternating light- and dark-gray dolomite beds; light-gray beds are mottled or laminated; dark-gray beds are locally mottled, laminated, or with white twig-like dolomite/calcite bodies (twiggy bodies) included; lower part (about 200 feet [60 m]) of blue-gray limestone streaked and mottled with yellow and red mudstone interlayered with light-colored laminated dolomite and with lenses of intraformational conglomerate; well stratified (medium to thick bedded) forming ridges and steps; thickness is 825 feet (250 m).

Cbh **Bluebird Dolomite and Herkimer Limestone, undivided** (Middle Cambrian) – *Bluebird* is dusky blue-gray dolomite or limestone with twiggy bodies and is very thick bedded forming ridges and ledges; Bluebird thickness is about 200 feet (60 m); *Herkimer* is light blue-gray limestone mottled and striped with yellow and red mudstone that is thin to medium bedded; unit of 20-foot-thick (6 m) green to tan shale exists about 180 feet (55 m) above base; oolitic and pisolitic near top; moderately resistant forming slopes and low cliffs; Herkimer thickness is 400 feet (120 m); combined unit thickness is 600 feet (180 m).

Cdt **Dagmar Dolomite and Teutonic Limestone, undivided** (Middle Cambrian) – *Dagmar* is medium-gray fine-grained laminated dolomite with minor interbedded light-gray limestone; distinctive unit is thin-bedded and weathers to creamy white color with a blocky fracture; Dagmar is about 75 feet (20 m) thick; *Teutonic* is light- and dark-gray limestone generally mottled and streaked with yellow-brown argillaceous lenses; oolite and pisolite beds common in lower and middle parts; locally contains *Girvanella* spherules; medium bedded, forming smooth cliffs and

ledges; Teutonic thickness is 420 feet (130 m); combined unit thickness is about 500 feet (150 m).

Cop **Ophir Formation** (Middle Cambrian) – Upper part is gray-green micaceous shale overlying a medial limestone interval of dark-gray limestone mottled and streaked with yellow-brown mudstone; lower part is gray-green shale with minor interlayered limestone, and near base is brown and purple sandstone; slope-forming unit; thickness is about 430 feet (130 m).

Ct **Tintic Quartzite** (Middle? and Lower? Cambrian) – Pink, white, brown, and greenish-gray quartzite that is medium to very thick bedded, cross-bedded, and fractured, containing shaly and conglomeratic zones; a thin, altered diabase flow is locally interbedded about 980 feet (300 m) above base; lower part is marked by a purple conglomerate unit 300 feet (90 m) thick; forms resistant ridges and rounded hills; approximately 2500 feet (760 m) thick.

Unconformity

Zbc **Big Cottonwood Formation** (Neoproterozoic) – Olive-green to brownish-green phyllitic shale, argillite, quartzite, and quartzite conglomerate; well bedded and slightly metamorphosed; age from Dehler and others (2010); only about 200 feet (60 m) exposed near south border of Boulter Peak quadrangle; maximum exposed thickness in the Tintic district is 1675 feet (510 m).

REFERENCES

- Allen, T., in preparation, Cenozoic geology of the Boulter Peak quadrangle, Tooele and Utah Counties, Utah: unpublished map for EDMAP project, and B.S. thesis, Brigham Young University, scale 1:24,000.
- Armin, R.A., 1979, Geology of the southeastern Stansbury Mountains and southern Onaqui Mountains, Tooele County, Utah with a paleoenvironmental study of part of the Oquirrh Group: San Jose, California, San Jose State University, M.S. thesis, 110 p., 1 plate, scale 1:48,000.
- Armin, R.A., and Moore, W.J., 1981, Geology of the southeastern Stansbury Mountains and southern Onaqui Mountains, Tooele County, Utah: U.S. Geological Survey Open-File Report 81-247, scale 1:24,000. [superceded USGS MF-921 (1978) of Onaqui Mtns South quad.]
- Biek, R.F., 2004, Geologic maps of the Saratoga Springs 7.5' and Cedar Fort 7.5' quadrangles, Utah County, Utah: Utah Geological Survey Maps 201 and 202, 3 plates, scale 1:24,000.
- Biek, R.F., 2005, Geologic map of the Jordan Narrows quadrangle, Salt Lake and Utah Counties, Utah: Utah Geological Survey Map 208, 2 plates, scale 1:24,000.
- Biek, R.F., 2006a, Geology of the Rose Canyon area, Salt Lake County, Utah – the exhumed flank of the Bingham volcanic center, *in* Harty, K.M., and Tabet, D.E., editors, Geology of northwest Utah: Utah Geological Association Publication 34, 21 p., CD.
- Biek, R.F., 2006b, Whole-rock geochemical and electron microprobe data for the Tickville Spring quadrangle, Utah: Utah Geological Survey Open-File Report 475, 7 p., available online, <<http://geology.utah.gov/online/ofr/ofr-475.pdf>>.
- Biek, R.F., Clark, D.L., Christiansen, E.H., 2009, Geologic map of the Soldiers Pass quadrangle, Utah County, Utah: Utah Geological Survey Map 235, 3 plates, scale 1:24,000, CD.
- Biek, R.F., Solomon, B.J., Keith, J.D., and Smith, T.W., 2005, Geologic map of the Tickville Spring quadrangle, Salt Lake and Utah Counties, Utah: Utah Geological Survey Map 214, 2 plates, scale 1:24,000.
- Budge, D.R., and Sheehan, P.M., 1980, Upper Ordovician through Middle Silurian of the eastern Great Basin, part 2, lithologic descriptions: Milwaukee Public Museum Contributions in Biology and Geology, no. 29, 80 p.

- Burr, T.N., and Currey, D.R., 1988, The Stockton Bar, *in* Machette, M.N., editor, In the footsteps of G.K. Gilbert – Lake Bonneville and neotectonics of the eastern Basin and Range Province, Guidebook for Field Trip 12, Geological Society of America Annual Meeting, Denver, Colorado: Utah Geological and Mineral Survey Miscellaneous Publication 88-1, p. 66-73.
- Burr, T.N., and Currey, D.R., 1992, Hydrographic modeling at the Stockton Bar, *in* Wilson, J.R., editor, Field guide to geologic excursions in Utah and adjacent areas of Nevada, Idaho, and Wyoming, for Geological Society of America Rocky Mountain Section Meeting, Ogden, Utah: Utah Geological and Mineral Survey Miscellaneous Publication 92-3, p. 207-219.
- Cashman, P.H., 1992, Structural geology of the northeastern Stansbury Mountains, *in* Wilson, J.R., editor, Field Guide to Geologic Excursions in Utah and adjacent areas of Nevada, Idaho, and Wyoming, for Geological Society of America, Rocky Mountain Section Meeting May 13-15, 1992: Utah Geological Survey Miscellaneous Publication 92-3, p. 171-178.
- Christiansen, E.H., Baxter, N., Ward, T., Zobell, E., Chandler, M.R., Dorais, M.J., Kowallis, B.J., Hart, G.L., and Clark, D.L., 2007, Cenozoic volcanism in the southern Lake Mountains, central Utah, *in* Willis, G.C., Hylland, M.D., Clark, D.L., and Chidsey, T.C., Jr., editors, Central Utah – Diverse Geology of a Dynamic Landscape: Utah Geological Association Publication 36, p. 123-142.
- Clark, D.L., 2008, Whole-rock geochemical data for the Granite Peak, Granite Peak SE, Dugway Proving Ground SW, Camels Back Ridge NE, Wig Mountain, Wig Mountain NE, Tabbys Peak, Tabbys Peak SE, Tabbys Peak SW, and Wildcat Mountain quadrangles, Utah: Utah Geological Survey Open-File Report 533, 4 p., also available online, <<http://geology.utah.gov/online/ofr/ofr-533.pdf>>.
- Clark, D.L., and Kirby, S.M., 2009, Reevaluating Cambrian stratigraphy in the Stansbury and northern Sheeprock Mountains, northwest Utah – A progress report, *in* Tripp, B.T., Krahulec, K., and Jordan, L., editors, Geology and Geologic Resources and Issues of Western Utah: Utah Geological Association Publication 38, p. 17-26, CD.
- Clark, D.L., Oviatt, C.G, and Page, D., 2008, Interim geologic map of Dugway Proving Ground and adjacent areas, parts of the Wildcat Mountain, Rush Valley, and Fish Springs 30' x 60' quadrangles, Tooele County, Utah: Utah Geological Survey Open-File Report 532, 3 plates, scale 1:75,000.
- Constenius, K.N., King, J.K., Clark, D.L., Ehler, J.B., compilers, 2010, Interim geologic map of the Provo 30' x 60' quadrangle, Utah and Wasatch Counties, Utah: Utah Geological Survey Open-File Report, scale 1:62,500, GIS data.

- Copfer, T.J., and Evans, J.P., 2005, Provisional geologic map of the Deseret Peak East 7.5' quadrangle, Tooele County, Utah: Utah Geological Survey Open-File Report 450, 32 p., 3 plates, scale 1:24,000, CD.
- Crittenden, M.D., Jr., 1963, New data on the isostatic deformation of Lake Bonneville: U.S. Geological Survey Professional Paper 454-E, 31 p.
- CRONUS-Earth Project, 2005, Draft sampling plan: Lake Bonneville Shorelines Sampling Trip, July 7-10, 2005. [CRONUS: Cosmic-Ray Produced Nuclide Systematics on Earth Project]; http://tesla.physics.purdue.edu/cronus/bonneville_shoreline_sampling_plan.pdf.
- Currey, D.R., 1982, Lake Bonneville – Selected features of relevance to neotectonic analysis: U.S. Geological Survey Open-File Report 82-1070, 30 p., 1 plate, scale 1:500,000.
- Currey, D.R., 1996, Final report of a geomorphological survey of surficial lineaments north of Hickman Knolls, Tooele County, Utah: *in* SWEC, 1997, Appendix 2C.
- Davis, B.L., 1959, Petrology and petrography of the igneous rocks of the Stansbury Mountains, Tooele County, Utah: Brigham Young University Research Studies, Geology Series, v. 6., no. 2.
- Dean, L.E., 1978, Eolian sand dunes of the Great Salt Lake Basin: *Utah Geology*, v. 5, no. 2, p. 103-111.
- Dehler, C.M., Fanning, C.M., Link, P.K., Kingsbury, E.M., and Rybczynski, D., 2010, Maximum depositional age and provenance of the Uinta Mountain Group and Big Cottonwood Formation, northern Utah - Paleogeography of rifting western Laurentia: *Geological Society of America Bulletin*, v. 122, no. 9/10, p. 1686-1699.
- Deino, A., and Keith, J.D., 1997, Ages of volcanic and intrusive rocks in the Bingham mining district, Utah, *in* John, D.A., and Ballantyne, G.H., editors, *Geology and ore deposits of the Oquirrh and Wasatch Mountains, Utah*: Society of Economic Geologists Guidebook Series, v. 29, p. 91-100.
- Disbrow, A.E., 1957, Preliminary geologic map of the Fivemile Pass quadrangle, Tooele and Utah Counties, Utah: U.S. Geological Survey Mineral Investigations Field Studies Map MF-131, 1 plate, scale 1:24,000.
- Disbrow, A.E., 1961, Geology of the Boulter Peak quadrangle, Tooele and Utah Counties, Utah: U.S. Geological Survey Geologic Quadrangle map GQ-141, 2 plates, scale 1:24,000.

- Fairbanks, R.G., Mortlock, R.A., Chiu, T., Cao, L., Kaplan, A., Guilderson, T.P., Fairbanks, T.W., Bloom, A.L., Grootes, P.M., and Nadeau, M., 2005, Radiocarbon calibration curve spanning 0 to 50,000 years BP based on paired $^{230}\text{Th}/^{234}\text{U}/^{238}\text{U}$ and ^{14}C dates on pristine corals: *Quaternary Science Reviews*, v. 24, p. 1781-1796;
<http://www.radiocarbon.ldeo.columbia.edu/research/radcarbcal.htm>.
- Gardner, P.M., and Kirby, S.M., in review, Hydrogeologic characterization and groundwater resources of Rush Valley, Tooele County, Utah, 2008-2010: U.S. Geological Survey, Scientific Investigations Report.
- Geomatrix Consultants, Inc., March 2001, Fault evaluation study and seismic hazard assessment at the Private Fuel Storage facility, Skull Valley, Utah (final report, volume I-III), prepared for Stone & Webster Engineering Corporation, Denver, Colorado.
- Gilbert, G.K., 1890, Lake Bonneville: U.S. Geological Survey Monograph 1, 438 p.
- Gillully, J., 1932, Geology and ore deposits of the Stockton and Fairfield quadrangles, Utah: U.S. Geological Survey Professional Paper 173, 171 p., 12 plates, scale 1:62,500.
- Godsey, H.S., Currey, D.R., and Chan, M.A., 2005, New evidence for an extended occupation of the Provo shoreline and implications for regional climate change, Pleistocene Lake Bonneville, Utah, USA: *Quaternary Research*, v. 63, p. 212-223.
- Gordon, M., Jr., Tooker, E.W., and Dutro, J.T., Jr., 2000, Type locality for the Great Blue Limestone in the Bingham Nappe, Oquirrh Mountains, Utah: U.S. Geological Survey Open-File Report 00-012, 61 p.
- Hintze, L.F., 1959, Ordovician regional relationships in north-central Utah and adjacent areas, *in* Williams, N.C., editor, Guidebook to the geology of the Wasatch and Uinta Mountains transition area: Intermountain Association of Petroleum Geologists Tenth Annual Field Conference Guidebook, p. 46-53.
- Hintze, L.F., 1980, Preliminary geologic map of the Fish Springs NE and Fish Springs SE quadrangles, Juab and Tooele Counties, Utah: U.S. Geological Survey Miscellaneous Field Studies Map MF-1147, scale 1:24,000.
- Hintze, L.F., and Davis, F. D., 2003, Geology of Millard County, Utah: Utah Geological Survey Bulletin 133, 305 p.
- Hintze, L.F., and Kowallis, B.J., 2009, Geologic history of Utah: Brigham Young University Geology Studies, Special Publication 9, 225 p.

- Hintze, L.F., and Robison, R.A., 1975, Middle Cambrian stratigraphy of the House, Wah Wah, and adjacent ranges in western Utah: Geological Society of America Bulletin, v. 86, p. 881-891.
- Hughen, K.A., Baillie, M.G.L., Bard, E., Bayliss, A., Beck, J.W., Bertrand, C.J.H., Blackwell, P.G., Buck, C.E., Burr, G.S., Cutler, K.B., Damon, P.E., Edwards, R.L., Fairbanks, R.G., Friedrich, M., Guilderson, T.P., Kromer, B., McCormac, F.G., Manning, S.W., Bronk Ramsey, C., Reimer, P.J., Reimer, R.W., Remmele, S., Southon, J.R., Stuiver, M., Talamo, S., Taylor, F.W., van der Plicht, J., and Weyhenmeyer, C.E., 2004, Marine radiocarbon age calibration, 26 - 0 ka BP: Radiocarbon v. 46, p. 1059-1086.
- Imbrie, J., Hays, J.D., Martinson, D.G., McIntyre, A., Mix, A.C., Morley, J.J., Pisias, N.G., Prell, W.L., and Shackleton, N.J., 1984, The orbital theory of Pleistocene climate – support from a revised chronology of the marine ^{18}O record, *in* Berger, A., Imbrie, J., Hays, J., Kukla, G., and Saltzman, B., editors, Milankovitch and Climate Part I: Dordrecht, Holland, Reidel, p. 269-306.
- Jordan, T.E., 1979a, Evolution of the Late Pennsylvanian-Early Permian western Oquirrh basin, Utah: Palo Alto, California, Stanford University, Ph.D thesis, 253 p.
- Jordan, T.E., 1979b, Lithofacies of the upper Pennsylvanian and lower Permian western Oquirrh Group, northwest Utah: Utah Geology, v. 6, no. 2, p. 41-56.
- Jordan, T.E., and Allmendinger, R.W., 1979, Upper Permian and Lower Triassic Stratigraphy of the Stansbury Mountains, Utah: Utah Geology, v. 6, no. 2., p. 69-74.
- Kirby, S.M., 2010a, Interim geologic map of the Lofgreen quadrangle, Tooele County, Utah: Utah Geological Survey Open-File Report 563, 17 p., 2 plates, scale 1:24,000, CD.
- Kirby, S.M., 2010b, Interim geologic map of the Vernon quadrangle, Tooele County, Utah: Utah Geological Survey Open-File Report 564, 18 p., 2 plates, scale 1:24,000, CD.
- Kirby, S.M., 2010c, Interim geologic map of the Vernon NE quadrangle, Tooele County, Utah: Utah Geological Survey Open-File Report 562, 10 p., 2 plates, scale 1:24,000, CD.
- Kirby, S.M., and Hurlow, H.A., in preparation, Hydrogeologic framework of the Rush Valley drainage basin, Tooele County, Utah: Utah Geological Survey Special Study.
- Krahulec, K.A., 2005, Rush Valley mining district, Tooele County, Utah, *in* Rasmussen, H., Crafford, E.J., O'Malley, P., and Callicrate, T., editors, Porphyry deposits of

- the Great Basin, Field Trip Guidebook 9: Geological Society of Nevada Symposium 2005 Window to the World, p. 75-80.
- Kummel, B., 1954, Triassic stratigraphy of southeastern Idaho and adjacent areas (Wyoming-Montana), *in* Shorter contributions to general geology: U.S. Geological Survey Professional Paper 254-H, p. H165-H194.
- Laes, D.Y.M., Krahulec, K.A., and Ballantyne, G.H., compilers, 1997, Geologic map of the Oquirrh Mountains, Utah, *in* John, D.A., and Ballantyne, G.H., editors, Geology and ore deposits of the Oquirrh and Wasatch Mountains, Utah: Society of Economic Geologists Guidebook Series, v. 29, plate 1, scale 1:62,500.
- Lanier, G., John, E.C., Swensen, A.J., Reid, J., Bard, C.E., Caddey, S.W., and Wilson, J.C., 1978, General geology of the Bingham mine, Bingham Canyon, Utah: Economic Geology, v. 73, no. 7, p. 1228-1241.
- Le Bas, M.J., Le Maitre, R.W., Streckheisen, A., and Zenettin, B., 1986, A chemical classification of volcanic rocks based on the total alkali-silica diagram: Journal of Petrology, v. 27, p. 745-750.
- Lindgren, W., and Loughlin, G.F., 1919, Geology and ore deposit of the Tintic mining district, Utah: U.S. Geological Survey Professional Paper 107, 282 p.
- Lufkin, J.L., 1965, Geology of the Stockton stock and related intrusives, Tooele County, Utah: Brigham Young University Geology Studies, v. 12, p. 149-164.
- Mako, D.A., 1999, A Post-mining view of the Mercur Gold District, Tooele County, Utah, 1999 Spring field trip guidebook – Bingham Canyon Mine, Barney’s Canyon Mine, Mercur Mine: Geological Society of Nevada, Elko Chapter, Special Publication 30.
- Maughan, D.T., 2001, Contributions to the mafic alkaline magmas to the Bingham porphyry Cu-Au-Mo deposit, Utah, U.S.A.: Provo, Brigham Young University, M.S. thesis, 238 p.
- Maurer, R.E., 1970, Geology of the Cedar Mountains, Tooele County, Utah: Salt Lake City, University of Utah, Ph.D. dissertation, 184 p., 10 plates, scale 1:43,700.
- McKean, A.P., Kowallis, B.J., and Christiansen, E.H., in preparation, Geologic map of the Allens Ranch 7.5' quadrangle, Utah County, Utah: unpublished map for EDMAP project, and M.S. thesis, Brigham Young University, scale 1:24,000.
- Middlemost, E.A.K., 1994, Naming materials in the magma/igneous rock system: Earth-Science Review, v. 37, p. 215-224.

- Moore, W.J., 1973, A summary of radiometric ages of igneous rocks in the Oquirrh Mountains, north-central Utah: *Economic Geology*, v. 68, no. 1, p. 97-101.
- Moore, W.J., Lanphere, M.A., and Obradovich, J.D., 1968, Chronology of intrusion, volcanism, and ore deposition at Bingham, Utah: *Economic Geology*, v. 63, no. 6, p. 612-621.
- Moore, W.J., and McKee, E.H., 1983, Phanerozoic magmatism and mineralization in the Tooele 1° x 2° quadrangle, Utah, *in* Miller, D.M., Todd, V.R., and Howard, K.A., editors, *Tectonic and stratigraphic studies in the eastern Great Basin: Geological Society of America Memoir 157*, p. 183-190.
- Moore, W.J., and Sorensen, M.L., 1977, Reconnaissance geologic map of northern Simpson Mountains, Davis Mountain, and adjacent areas, Tooele County, Utah: U.S. Geological Survey Miscellaneous Field Studies Map MF-905, 1 plate, scale 1:48,000.
- Moore, W.J., and Sorensen, M.L., 1979, Geologic map of the Tooele 1° x 2° quadrangle, Utah: U.S. Geological Survey Miscellaneous Investigation Series Map I-1132, scale 1:250,000.
- Morris, H.T., and Lovering, T.S., 1961, Stratigraphy of the East Tintic Mountains, Utah: U.S. Geological Survey Professional Paper 1024, 203 p.
- Moyle, R.W., 1959, Stratigraphy of the southern Oquirrh Mountains, Manning Canyon Shale: *Utah Geological Society Guidebook 14*, p. 59-92.
- Mulvey, W.E., 1985, Reconstruction and interpretation of Late Pleistocene equilibrium-line altitudes in the Lake Bonneville region: Salt Lake City, MS thesis, University of Utah, 65 p.
- Murchison, S.B., 1989, Fluctuation history of Great Salt Lake, Utah, during the last 13,000 years: Salt Lake City, University of Utah, Ph.D. dissertation, 137 p.
- New Mexico Geochronology Research Laboratory and Utah Geological Survey, 2006, ⁴⁰Ar/³⁹Ar geochronology results for the Cave Canyon, Fountain Green North, Hilgard Mountain, Pine Park, Skinner Peaks, Tickville Spring, and Veyo quadrangles, Utah: Utah Geological Survey Open-File Report 473, variously paginated, also available online, <<http://geology.utah.gov/online/ofr/ofr-473.pdf>>.
- Nygreen, P.W., 1958, The Oquirrh formation – stratigraphy of the lower portion in the type area and near Logan, Utah: *Utah Geological and Mineral Survey Bulletin*, no. 61, 67 p.
- Osborn, G., and Bevis, K., 2001, Glaciation in the Great Basin of the western United States: *Quaternary Science Reviews*, v. 20, p. 1377-1410.

- Oviatt, C.G., 1987, Lake Bonneville stratigraphy at the Old River Bed: *American Journal of Science*, v. 287, p. 383-398.
- Oviatt, C.G., 1997, Lake Bonneville and global climate change: *Geology*, v. 25, p. 155-158.
- Oviatt, C.G., Currey, D.R., and Miller, D.M., 1990, Age and paleoclimatic significance of the Stansbury shoreline of Lake Bonneville, northeastern Great Basin: *Quaternary Research*, v. 33, p. 291-305.
- Oviatt, C.G., Currey, D.R., and Sack, D., 1992, Radiocarbon chronology of Lake Bonneville, eastern Great Basin, USA: *Palaeogeography, Palaeoclimatology, Palaeoecology*, v. 99, p. 225-241.
- Oviatt, C.G., Madsen, D.B., and Schmitt, D.N., 2003, Late Pleistocene and early Holocene rivers and wetlands in the Bonneville basin of western North America: *Quaternary Research*, v. 60 p. 200-210.
- Oviatt, C.G., Miller, D.M., McGeehin, J.P., Zachary, C., and Mahan, S., 2005, The Younger Dryas phase of Great Salt Lake, Utah, USA: *Palaeogeography, Palaeoclimatology, Palaeoecology*, v. 219, no. 3-4, p. 263-284.
- Oviatt, C.G., Sack, D., and Felger, T.J., 1994, Quaternary geologic map of the Old River Bed, and vicinity, Millard, Juab, and Tooele Counties, Utah: *Utah Geological Survey Map 161*, 24 p., 1 plate, scale 1:62,500.
- Oviatt, C.G., and Thompson, R.S., 2002, Recent developments in the study of Lake Bonneville since 1980, *in* Gwynn, J.W., editor, *Great Salt Lake – An overview of change*: Utah Department of Natural Resources Special Publication, p. 1-6.
- Parry, W.T., Wilson, P.N., Moser, D., and Heizler, M.T., 2001, U-Pb dating of zircon and $^{40}\text{Ar}/^{39}\text{Ar}$ dating of biotite at Bingham, Utah: *Economic Geology*, v. 96, p. 1671-1683.
- Perkins, M.E., Nash, W.P., Brown, F.H., and Fleck, R.J., 1995, Fallout tuffs of Trapper Creek, Idaho—A record of Miocene explosive volcanism in the Snake River Plain volcanic province: *Geological Society of America Bulletin*, v. 107, no. 12, p. 1484-1506.
- Perkins, M.E., Brown, F.H., Nash, W.P., McIntosh, W., and Williams, S.K., 1998, Sequence, age, and source of silicic fallout tuffs in middle to late Miocene basins of the northern Basin and Range province: *Geological Society of America Bulletin*, v. 110, no. 3, p. 344-360.

- Perkins, M.E., and Nash, B.P., 2002, Explosive silicic volcanism of the Yellowstone hotspot – The ash fall tuff record: *Geological Society of America Bulletin*, v. 114, no. 3, p. 367-381.
- Proctor, P.D., and Clark, D.L., 1956, The Curley limestone – and unusual biostrome in central Utah: *Journal of Sedimentary Petrology*, v. 26, no. 4, p. 313-321.
- Pulsifer, T., 2000, The correlation of Eocene extrusive block and ash flows to intrusions at the Bingham copper porphyry system, Utah: Provo, Utah, Brigham Young University, M.S. thesis, 104 p.
- Rigby, J.K., 1958, Geology of the Stansbury Mountains, eastern Tooele County, Utah, *in* Rigby, J.K., editor, *Geology of the Stansbury Mountains, Tooele County, Utah*: Utah Geological Society, *Guidebook to the Geology of Utah*, no. 13, p. 1-134, map scale 1:63,360.
- Rigby, J.K., 1959a, Upper Devonian unconformity in central Utah: *Geological Society of America Bulletin*, v. 70, p. 207-218.
- Rigby, J.K., 1959b, Stratigraphy of the southern Oquirrh Mountains, lower Paleozoic succession, *in* Bissell, H.J., editor, *Geology of the southern Oquirrh Mountains and Fivemile Pass – Northern Boulter Mountain area, Tooele and Utah Counties, Utah*: Utah Geological Society *Guidebook*, no. 14, p. 9-36.
- Sack, D., 1993, Quaternary geologic map of Skull Valley, Tooele County, Utah: Utah Geological Survey Map 150, 16 p., 1 plate, scale 1:100,000.
- Sandberg, C.A., and Gutschick, R.C., 1984, Distribution, microfauna, and source-rock potential of Mississippian Delle Phosphatic Member of Woodman formation and equivalents, Utah and adjacent states, *in* Woodward, J., Meissner, F.F., and Clayton, J.L., editors, *Hydrocarbon source rocks of the Greater Rocky Mountain region: Denver, Colorado*, Rocky Mountain Association of Geologists, p. 135-178.
- Sorensen, M.L., 1982, Geologic map of the Stansbury roadless areas, Tooele County, Utah: U.S. Geological Survey *Miscellaneous Field Studies Map MF-1353-C*, scale 1:62,500.
- Staatz, M.H., 1972, Geologic map of the Dugway Proving Ground SW quadrangle, Tooele County, Utah: U.S. Geological Survey Map CQ-992, scale 1:24,000.
- Staatz, M.H., and Carr, W.J., 1964, Geology and mineral deposits of the Thomas and Dugway Ranges, Juab and Tooele Counties, Utah: U.S. Geological Survey *Professional Paper 415*, 188 p., 9 pl.

- Stuiver, M., and Reimer, P.J., 1993, Extended ^{14}C database and revised CALIB radiocarbon calibration program: Radiocarbon, v. 35, p. 215-230.
- Stuiver, M., Reimer, P.J., and Reimer, R., 2005, CALIB radiocarbon calibration, version 5.0; <http://radiocarbon.pa.qub.ac.uk/calib/>.
- SWEC (Stone & Webster Engineering Corporation), 1997, Safety Analysis Report, Private Fuel Storage Facility, Skull Valley, Utah, prepared for Private Fuel Storage LLC, 2 volumes.
- Swenson, A.J., 1975, Sedimentary and igneous rocks of the Bingham mining district, *in* Bray, R.E., and Wilson, J.C., editors, Guidebook to the Bingham mining district: Society of Economic Geologists and Kennecott Copper Corporation, Bingham Canyon, Utah, p. 21-39.
- Swenson, A.J., and Kennecott staff, compilers, 1991, Geologic map of the Bingham district, *in* Black, J.E., and Babcock, R.C., editors, Guidebook to the geology and ore deposits of the Bingham mining district and northern Oquirrh Mountains, Utah: RTZ Group Mining and Exploration Conference, Salt Lake City, Utah, map (Plate 1), scale 1:24,000.
- Teichert, J.A., 1958, Geology of the southern Stansbury Range, Tooele County, Utah: Salt Lake City, University of Utah, M.S. thesis, 79 p., scale 1:20,000.
- Teichert, J.A., 1959, Geology of the southern Stansbury Range, Tooele County, Utah: Utah Geological and Mineralogical Survey Bulletin 65, 75 p., 2 plates, scale 1:96,000.
- Tooker, E.W., 1983, Variations in structural style and correlation of thrust plates in the Sevier foreland thrust belt, Great Salt Lake area, Utah, *in* Miller, D.M., editor, Tectonic and stratigraphic studies in the eastern Great Basin: Geological Society of America Memoir 157, p. 61-73.
- Tooker, E.W., 1987, Preliminary geologic maps, cross sections, and explanation pamphlet for the Ophir and Mercur 7 ½-minute quadrangles, Utah: U.S. Geological Survey Open-File Report 87-152, 18 p., 3 plates, scale 1:24,000.
- Tooker, E.W., 1992, Preliminary geologic map of the Lowe Peak 7 ½-minute quadrangle, Tooele, Utah, and Salt Lake Counties, Utah: U.S. Geological Survey Open-File Report 92-404, 1 plate, scale 1:24,000.
- Tooker, E.W., 1999, Geology of the Oquirrh Mountains, Utah: USGS OF-99-571, map scale 1:50,000.
- Tooker, E.W., and Roberts, R.J., 1970, Upper Paleozoic rocks in the Oquirrh Mountains and Bingham mining district, Utah, with a section on biostratigraphy and

- correlation by Gordon, M., Jr., and Duncan, H.M.: U.S. Geological Survey Professional Paper 629-A, 76 p.
- Tooker, E.W., and Roberts, R.J., 1971, Structures related to thrust faults in the Stansbury Mountains, Utah: U.S. Geological Survey Professional Paper 750-B, p. B1-B12.
- Tooker, E.W. and Roberts, R.J., 1988, Interim geologic maps and explanation pamphlet for parts of the Stockton and Lowe Peak 7 ½-minute quadrangles, Utah: U.S. Geological Survey Open-File Report 88-280, 20 p., 2 plates, scale 1:24,000.
- Tooker, E.W. and Roberts, R.J., 1992, Preliminary geologic map of the Stockton 7 ½-minute quadrangle, Tooele County, Utah: U.S. Geological Survey Open-File Report 92-385, 22 p., 1 plate, scale 1:24,000.
- Tooker, E.W. and Roberts, R.J., 1998, Geologic map of the Oquirrh Mountains and adjoining South and western Traverse Mountains, Tooele, Salt Lake, and Utah Counties, Utah: U.S. Geological Survey Open-File Report 98-581, 2 plates, scale 1:50,000.
- Utah Geological Survey and New Mexico Geochronology Research Laboratory, 2007, ⁴⁰Ar/³⁹Ar geochronology results for the Tintic Mountain and Champlin Peak quadrangles, Utah: Utah Geological Survey Open-File Report 505, variously paginated, also available online, <<http://geology.utah.gov/online/ofr/ofr-505.pdf>>.
- Utah Geological Survey and New Mexico Geochronology Research Laboratory, 2009a, ⁴⁰Ar/³⁹Ar geochronology results for the Granite Peak, Granite Peak SE, and Camels Back Ridge NE quadrangles, Utah: Utah Geological Survey Open-File Report 542, variously paginated, also available online, <<http://geology.utah.gov/online/ofr/ofr-542.pdf>>.
- Utah Geological Survey and New Mexico Geochronology Research Laboratory, 2009b, ⁴⁰Ar/³⁹Ar geochronology results for the Blind Lake, Deer Creek Lake, Flat Top, Henrie Knolls, Tabbys Peak, Tabbys Peak SW, Wig Mountain, and Wig Mountain NE quadrangles, Utah: Utah Geological Survey Open-File Report 547, variously paginated, also available online, <<http://geology.utah.gov/online/ofr/ofr-547.pdf>>.
- Valora, P.J., 1968, Glaciation of The Jumpoff, Oquirrh Mountains, Utah: Provo, Brigham Young University, M.S. thesis.
- Waite, K.A., 1996, Petrogenesis of the volcanic and intrusive rocks associated with the Bingham porphyry Cu-Mo deposit, Utah: Provo, Utah, Brigham Young University, M.S. thesis, 143 p.
- Waite, K.A., Keith, J.D., Christiansen, E.H., Whitney, J.A., Hattori, K., Tingey, D.G., and Hook, C.J., 1997, Petrogenesis of the volcanic and intrusive rocks associated

- with the Bingham Canyon porphyry Cu-Au-Mo deposit, Utah, *in* John, D.A., and Ballantyne, G.H., editors, *Geology and ore deposits of the Oquirrh and Wasatch Mountains, Utah: Society of Economic Geologists Guidebook Series*, v. 29, p. 69-90.
- Webster, G.D., Gordon, M., Jr., Langenheim, R.L., and Henry, T.W., 1984, Road logs for the Mississippian-Pennsylvanian boundary in the eastern Great Basin – Salt Lake City, Utah, to Las Vegas, Nevada (Field Trip 1), *in* Lintz, J., Jr., editor, *Western geological excursions: Geological Society of America Annual Meeting, Field Trip Guidebook*, v. 1, p. 1-86.
- Welsh, J.E., and James, A.H., 1961, Pennsylvanian and Permian stratigraphy of the central Oquirrh Mountains, Utah, *in* Cook, D.R., editor, *Geology of the Bingham mining district and northern Oquirrh Mountains: Utah Geological Society Guidebook to the Geology of Utah*, no. 16, p. 1-16.
- Welsh, J.E., and James, A.H., 1998 (revised), Reconnaissance traverse and measured section of part of the South Mountain quadrangle, Tooele County, Utah: unpublished data submitted to the Utah Geological Survey.
- Wright, R.W., 1961, Stratigraphic and tectonic interpretation of Oquirrh Formation, Stansbury Mountains, Utah: *Brigham Young University Geology Studies*, v. 8, p. 147-166.

ACKNOWLEDGMENTS

We thank Rachel Quist and Jason Raff (U.S. Army Dugway Proving Ground) and Jeff Fitzmayer (Parsons) for logistical and technical assistance with the DPG area mapping. The New Mexico Geochronology Research Laboratory, under the supervision of Matthew Heisler, conducted the $^{40}\text{Ar}/^{39}\text{Ar}$ dating. Additional geochronology data are pending at the Nevada Isotope Geochronology Laboratory (University of Nevada, Las Vegas) operated by Terry Spell and Kathleen Zanetti. The late John Welsh contributed to the understanding of Permian-Pennsylvanian strata of this region and shared much of his unpublished data. A.J. Wells (independent paleontologist) identified fusulinids and reviewed Maurer's fusulinid data, and Scott Ritter (Brigham Young University) identified conodonts for biostratigraphic control. UGS staff Robert Biek, Grant Willis, and Robert Ressetar reviewed and improved this map, Jon King and Ken Krahulec provided technical assistance on geologic issues, Kent Brown prepared the GIS data and set up digital cartography, and Buck Ehler, Basia Matyjasik, Rich Emerson, Jay Hill, Lori Douglas, Paul Kuehne, and Jim Parker assisted in preparation of the map and explanatory materials.

Figure Captions:

Figure 1. Location map showing primary geographic features in the Rush Valley 30' x 60' quadrangle, years 1, 2 and 3 map areas, and hydrogeologic framework study area. TAD is Tooele Army Depot. The year 1 map area includes part of the Dugway Proving Ground and adjacent areas mapping project by Clark and others (2008). Gardner and Kirby (in review) and Kirby and Hurlow (in preparation) are conducting the Rush Valley hydrogeologic study.

Figure 2. Index map showing primary sources of geologic mapping in part of the Rush Valley 30' x 60' quadrangle, 7.5' quadrangles, and hydrogeologic framework study boundary.

Figure 3. Comparison of Oquirrh strata of the southern Cedar Mountains. The stratigraphy used in this map for the Lower Permian (Wolfcampian) and Pennsylvanian formations is based on that of the Oquirrh Mountains/Bingham mining district.

Figure 4. Comparison of Cambrian stratigraphy of the Stansbury Mountains. The stratigraphy used in this map is the western Utah type rather than the East Tintic type.

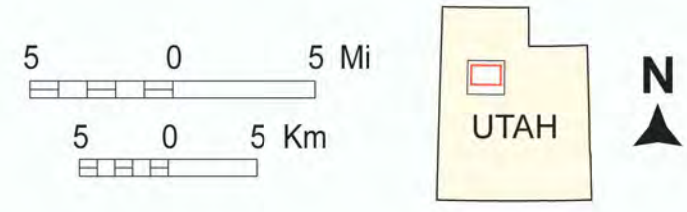
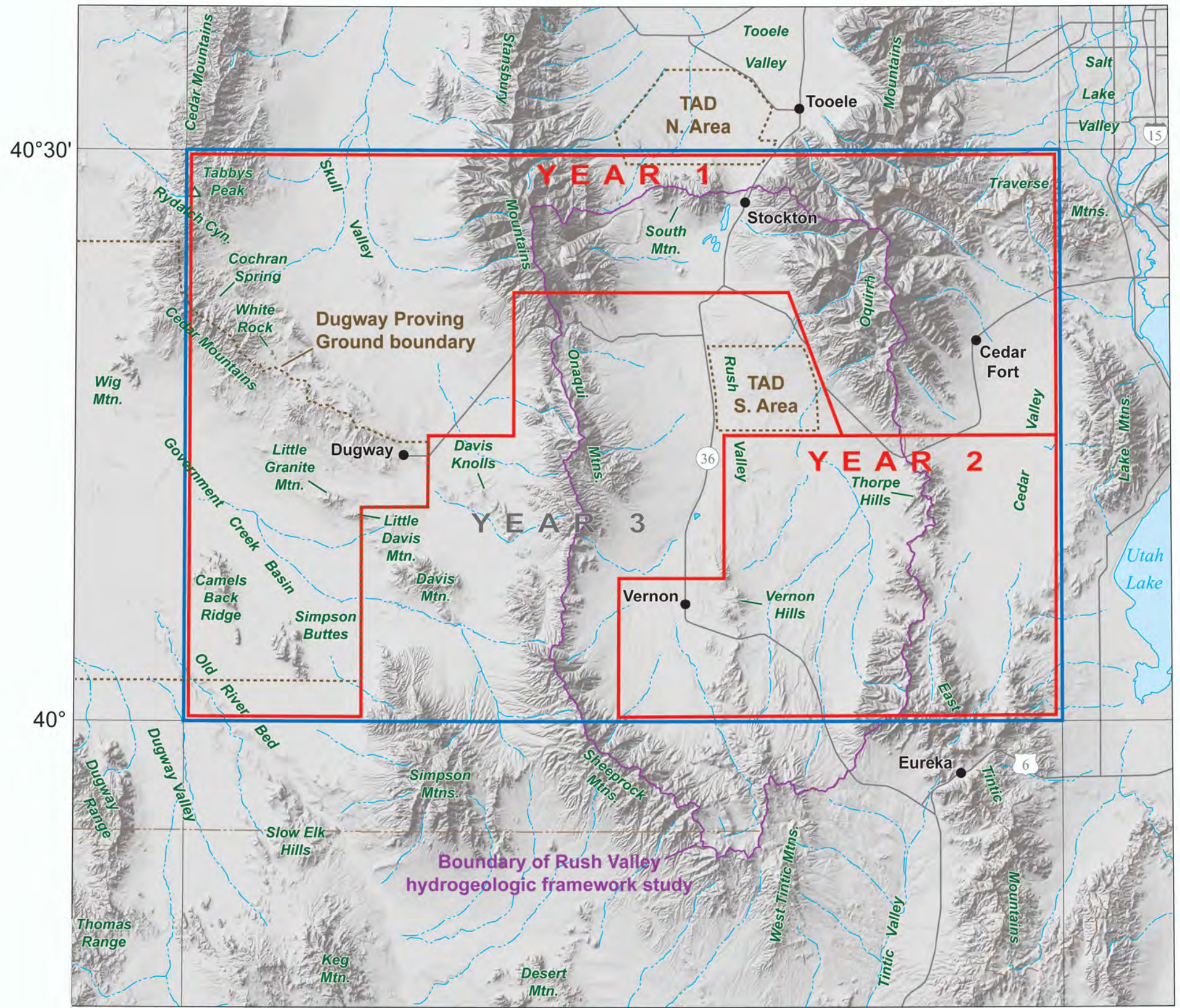

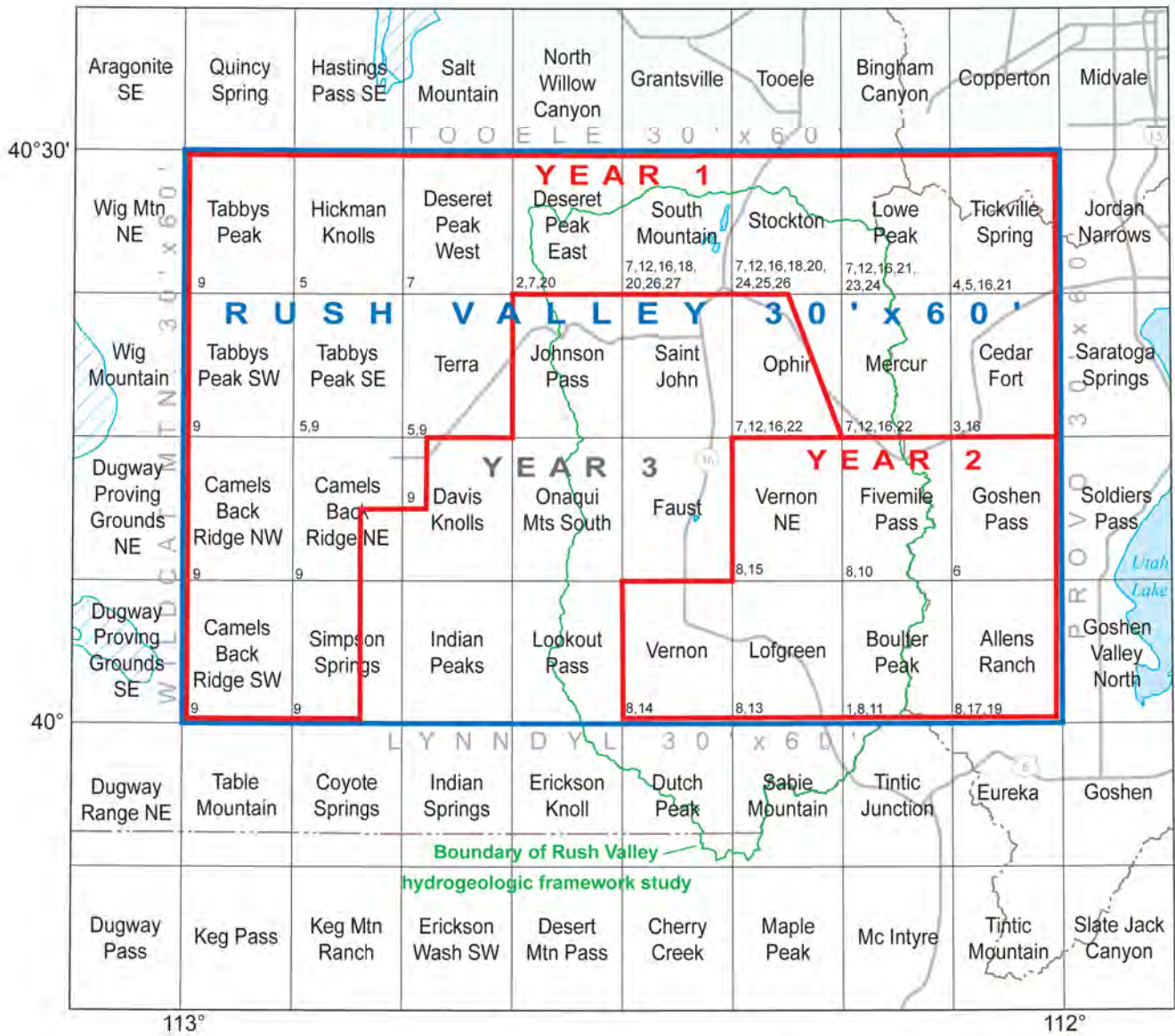

Text after figure 2

Sources of Geologic Map Data

Primary sources of geologic map data; numbers correspond to index map (figure 2).

1. Allen, T., in preparation, Cenozoic geology of the Boulter Peak quadrangle, Tooele and Utah Counties, Utah: unpublished map for EDMAP project, and B.S. thesis, Brigham Young University, scale 1:24,000.
2. Armin, R.A., and Moore, W.J., 1981, Geology of the southeastern Stansbury Mountains and southern Onaqui Mountains, Tooele County, Utah: U.S. Geological Survey Open-File Report 81-247, scale 1:24,000. [superceded U.S. Geological Survey Miscellaneous Field Studies Map MF-921 (1978) of Onaqui Mountains South quadrangle]
3. Biek, R.F., 2004, Geologic maps of the Saratoga Springs 7.5' and Cedar Fort 7.5' quadrangles, Utah County, Utah: Utah Geological Survey Maps 201 and 202, 3 plates, scale 1:24,000.
4. Biek, R.F., Solomon, B.J., Keith, J.D., and Smith, T.W., 2005, Geologic map of the Tickville Spring quadrangle, Salt Lake and Utah Counties, Utah: Utah Geological Survey Map 214, 2 plates, scale 1:24,000.
5. Clark, D.L. (Utah Geological Survey), 2008-2009, photogeologic and limited field mapping.
6. Clark, D.L. (Utah Geological Survey), 2009-2010, photogeologic and limited field mapping
7. Clark, D.L., and Kirby, S.M. (Utah Geological Survey), 2008-2009, photogeologic and limited field mapping.
8. Clark, D.L., and Kirby, S.M. (Utah Geological Survey), 2009-2010, photogeologic and limited field mapping.
9. Clark, D.L., Oviatt, C.G, and Page, D., 2008, Interim geologic map of Dugway Proving Ground and adjacent areas, parts of the Wildcat Mountain, Rush Valley, and Fish Springs 30' x 60' quadrangles, Tooele County, Utah: Utah Geological Survey Open-File Report 532, 3 plates, scale 1:75,000.
10. Disbrow, A.E., 1957, Preliminary geologic map of the Fivemile Pass quadrangle, Tooele and Utah Counties, Utah: U.S. Geological Survey Mineral Investigations Field Studies Map MF-131, 1 plate, scale 1:24,000.

11. Disbrow, A.E., 1961, Geology of the Boulter Peak quadrangle, Tooele and Utah Counties, Utah: U.S. Geological Survey Geologic Quadrangle map GQ-141, 2 plates, scale 1:24,000.
12. Gillully, J., 1932, Geology and ore deposits of the Stockton and Fairfield quadrangles, Utah: U.S. Geological Survey Professional Paper 173, 171 p., 12 plates, scale 1:62,500.
13. Kirby, S.M., 2010a, Interim geologic map of the Lofgreen quadrangle, Tooele County, Utah: Utah Geological Survey Open-File Report 563, 17 p., 2 plates, scale 1:24,000, CD.
14. Kirby, S.M., 2010b, Interim geologic map of the Vernon quadrangle, Tooele County, Utah: Utah Geological Survey Open-File Report 564, 18 p., 2 plates, scale 1:24,000, CD.
15. Kirby, S.M., 2010c, Interim geologic map of the Vernon NE quadrangle, Tooele County, Utah: Utah Geological Survey Open-File Report 562, 10 p., 2 plates, scale 1:24,000, CD.
16. Laes, D.Y.M., Krahulec, K.A., Ballantyne, G.H., compilers, 1997, Geologic map of the Oquirrh Mountains, Utah, *in* John, D.A., and Ballantyne, G.H., editors, Geology and ore deposits of the Oquirrh and Wasatch Mountains, Utah: Society of Economic Geologists Guidebook, v. 29, 256 p., map (Plate 1), scale 1:62,500.
17. McKean, A.P., Kowallis, B.J., and Christiansen, E.H., in preparation, Geologic map of the Allens Ranch 7.5' quadrangle, Utah County, Utah: unpublished map for EDMAP project, and M.S. thesis, Brigham Young University, scale 1:24,000.
18. Nelson, D., and Jewell, P., in preparation, Surficial geologic map of the south parts of the South Mountain and Stockton quadrangles, Tooele County, Utah: unpublished map for EDMAP project, University of Utah, scale 1:24,000.
19. Proctor, P.D., 1985, Preliminary geologic map of the Allens Ranch quadrangle, North Tintic District, Utah County, Utah: Utah Geological and Mineral Survey Open-File Report 69, 18 p., 2 plates, scale 1:24,000.
20. Solomon, B.J., 1993, Quaternary geologic maps of Tooele Valley and the West Desert Hazardous Industry Area, Tooele County, Utah: Utah Geological Survey Open-File Report 296, 48 p., 20 plates, scale 1:24,000.
21. Swenson, A.J., and Kennecott staff, compilers, 1991, Geologic map of the Bingham district, *in* Black, J.E., and Babcock, R.C., editors, Guidebook to the geology and ore deposits of the Bingham mining district and northern Oquirrh

- Mountains, Utah: RTZ Group Mining and Exploration Conference, Salt Lake City, Utah, map (Plate 1), scale 1:24,000.
22. Tooker, E.W., 1987, Preliminary geologic maps, cross sections, and explanation pamphlet for the Ophir and Mercur 7 ½-minute quadrangles, Utah: U.S. Geological Survey Open-File Report 87-152, 18 p., 3 plates, scale 1:24,000.
 23. Tooker, E.W., 1992, Preliminary geologic map of the Lowe Peak 7 ½-minute quadrangle, Tooele, Utah, and Salt Lake Counties, Utah: U.S. Geological Survey Open-File Report 92-404, 1 plate, scale 1:24,000.
 24. Tooker, E.W. and Roberts, R.J., 1988, Interim geologic maps and explanation pamphlet for parts of the Stockton and Lowe Peak 7 ½-minute quadrangles, Utah: U.S. Geological Survey Open-File Report 88-280, 20 p., 2 plates, scale 1:24,000.
 25. Tooker, E.W. and Roberts, R.J., 1992, Preliminary geologic map of the Stockton 7 ½-minute quadrangle, Tooele County, Utah: U.S. Geological Survey Open-File Report 92-385, 22 p., 1 plate, scale 1:24,000.
 26. Tooker, E.W. and Roberts, R.J., 1998, Geologic map of the Oquirrh Mountains and adjoining South and western Traverse Mountains, Tooele, Salt Lake, and Utah Counties, Utah: U.S. Geological Survey Open-File Report 98-581, 2 plates, scale 1:50,000.
 27. Welsh, J.E., and James, A.H., 1998 (revised), Reconnaissance traverse and measured section of part of the South Mountain quadrangle, Tooele County, Utah: unpublished data submitted to UGS.

Additional data sources used or considered for map preparation; not indicated in figure 2.

Barnhard, T.P., and Dodge, R.L., 1988, Map of fault scarps formed on unconsolidated sediments, Tooele 1° x 2° quadrangle, northwestern Utah: U.S. Geological Survey Miscellaneous Field Studies Map MF-1990, scale 1:250,000.

Black, B.D., Hecker, S., Hylland, M.D., Christenson, G.E., and McDonald, G.N., 2003, Quaternary fault and fold database and map of Utah: Utah Geological Survey Map 193DM, scale 1:500,000, CD.

Black, B.D., Solomon, B.J., and Harty, K.M., 1999, Geology and geologic hazards of Tooele Valley and the West Desert Hazardous Industry Area, Tooele County, Utah: Utah Geological Survey Special Study 96, 65 p., 6 plates, scale 1:100,000.

Bucknam, R.C., 1977, Map of suspected fault scarps in unconsolidated deposits, Tooele 2° sheet, Utah: U.S. Geological Survey, Open-File Report 77-495, scale 1:250,000.

Cook, K.L., Bankey, V., Mabey, D.R., and DePangher, M., 1989, Complete Bouguer gravity anomaly map of Utah: Utah Geological and Mineral Survey Map 122, scale 1:500,000.

Copfer, T.J., and Evans, J.P., 2005, Provisional geologic map of the Deseret Peak East 7.5' quadrangle, Tooele County, Utah: Utah Geological Survey Open-File Report 450, 32 p., 3 plates, scale 1:24,000, CD.

Currey, D.R., 1982, Lake Bonneville – Selected features of relevance to neotectonic analysis: U.S. Geological Survey Open-File Report 82-1070, 30 p., 1 plate, scale 1:500,000.

Everitt, B.L., and Kaliser, B.N., 1980, Geology for assessment of seismic risk in the Tooele and Rush Valleys, Tooele County, Utah: Utah Geological Survey Special Study 51, 33 p., 7 plates, scale 1:50,000.

Geomatrix Consultants, Inc., March 2001, Fault evaluation study and seismic hazard assessment, revision 1, Private Fuel Storage Facility, Skull Valley, Utah, prepared for Stone & Webster Engineering Corporation, 3 volumes.

Groff, S.L., 1957, Geology of the West Tintic Range and vicinity, Tooele, and Juab Counties, Utah: Salt Lake City, University of Utah, Ph.D. dissertation, 183 p., 4 plates, scale 1:21,120.

Harty, K.M., 1992, Landslide map of the Rush Valley 30' x 60' quadrangle, Utah: Utah Geological Survey Open-File Report 254, 10 p., 1 plate, scale 1:100,000.

- Hurlow, H.A., 2004, The geology of Cedar Valley, Utah County, Utah, and its relation to ground-water conditions: Utah Geological Survey Special Study 109, 74 p., 4 plates, map scale 1:100,000, CD.
- Johnson, J.B., Jr., and Cook, K.L., 1957, Regional gravity survey of parts of Tooele, Juab, and Millard Counties, Utah: *Geophysics*, v. 22, no. 1, p. 48-61.
- Maurer, R.E., 1970, Geology of the Cedar Mountains, Tooele County, Utah: Salt Lake City, University of Utah, Ph.D. dissertation, 184 p., 10 plates, scale 1:43,700.
- Moore, W.J., and McKee, E.H., 1983, Phanerozoic magmatism and mineralization in the Tooele 1° x 2° quadrangle, Utah, *in* Miller, D.M., Todd, V.R., and Howard, K.A., editors, *Tectonic and stratigraphic studies in the eastern Great Basin: Geological Society of America Memoir 157*, p. 183-190.
- Moore, W.J., and Sorensen, M.L., 1977, Reconnaissance geologic map of northern Simpson Mountains, Davis Mountain, and adjacent areas, Tooele County, Utah: U.S. Geological Survey Miscellaneous Field Studies Map MF-905, 1 plate, scale 1:48,000.
- Moore, W.J., and Sorensen, M.L., 1979, Geologic map of the Tooele 1° x 2° quadrangle, Utah: U.S. Geological Survey Miscellaneous Investigation Series Map I-1132, scale 1:250,000.
- Morris, H.R., 1987, Preliminary geologic structure map of the Delta 2° quadrangle and adjacent areas, west-central Utah: U.S. Geological Survey Open-File Report 87-189, scale 1:250,000.
- Morris, H.T., and Lovering, T.S., 1961, Stratigraphy of the East Tintic Mountains, Utah, with a section on Quaternary deposits by H.D. Goode: U.S. Geological Survey Professional Paper 361, 145 p., 5 plates, map scale 1:96,000.
- Mulvey, W.E., 1985, Reconstruction and interpretation of Late Pleistocene equilibrium-line altitudes in the Lake Bonneville region: Salt Lake City, M.S. thesis, University of Utah, 65 p. [unpublished mapping for M.S. thesis].
- Olig, S.S., Gorton, A.E., and Chadwell, L., 1999, Mapping and Quaternary fault scarp analysis of the Mercur and West Eagle Hill faults, Wasatch Front, Utah: unpublished technical report submitted to the U.S. Geologic Survey, NEHRP Award No. 1434-HQ-97-GR-03154.
- Rigby, J.K., 1958, Geology of the Stansbury Mountains, eastern Tooele County, Utah, *in* Rigby, J.K., editor, *Geology of the Stansbury Mountains, Tooele County, Utah: Utah Geological Society, Guidebook to the Geology of Utah*, no. 13, p. 1-134, map scale 1:63,360.

Sack, D., 1993, Quaternary geologic map of Skull Valley, Tooele County, Utah: Utah Geological Survey Map 150, 16 p., 1 plate, scale 1:100,000.

Sorensen, M.L., 1982, Geologic map of the Stansbury roadless areas, Tooele County, Utah: U.S. Geological Survey Miscellaneous Field Studies Map MF-1353-C, scale 1:62,500.

Teichert, J.A., 1958, Geology of the southern Stansbury Range, Tooele County, Utah: Salt Lake City, University of Utah, M.S. thesis, 79 p., scale 1:20,000.

Maurer (1970)

Time-stratigraphic unit	Cochran Spring section Feet (Meters)	Overall Feet (Meters)	Oquirrh Formation unit
PERMIAN Wolfcampian	340+ (104+)	1935+ - 2750 (590+ - 838)	Unit 5
PENNSYLVANIAN Virgilian	2762 (842)	2762 - 3000 (842 - 915)	Unit 4
	2556 (779)	2556 - 3000+ (779 - 915+)	Unit 3
	715 (218)	715 - 1400 (218 - 427)	Unit 2
	434 (132)	434 (132)	Unit 1
MISS. Chest.			
Total Thickness	6807 (2075)	8402+ - 10,584+ (2562+ - 3229+)	

This Map

Map unit	Cochran Spring section Feet (Meters)	Overall Feet (Meters)	Sample Numbers	Time-stratigraphic unit			
PPO	Pofc	2713 (827)	3500 (1070)	— D-60	Wolfcampian	Lower	PERMIAN
	Pobm	1000 (305) — fault —	2800 (850)	— D-75 D-69 — D-76 D-68 — D-52 D-57 — D-71	Misso.-Virgil.	Upper	PENNSYLVANIAN
	Pobp	fault / 2660 (811)	5400 (1650)	— D-70	Atokan-Desmoinesian	Middle	
	Powc	500 (150)	500-800 (150-245)	— D-50	Morrowan	Lower	
		6873 (2095)	12,350 (3770)				

STANSBURY MOUNTAINS (Rigby, 1958; Teichert, 1958, 1959)
East Tintic nomenclature

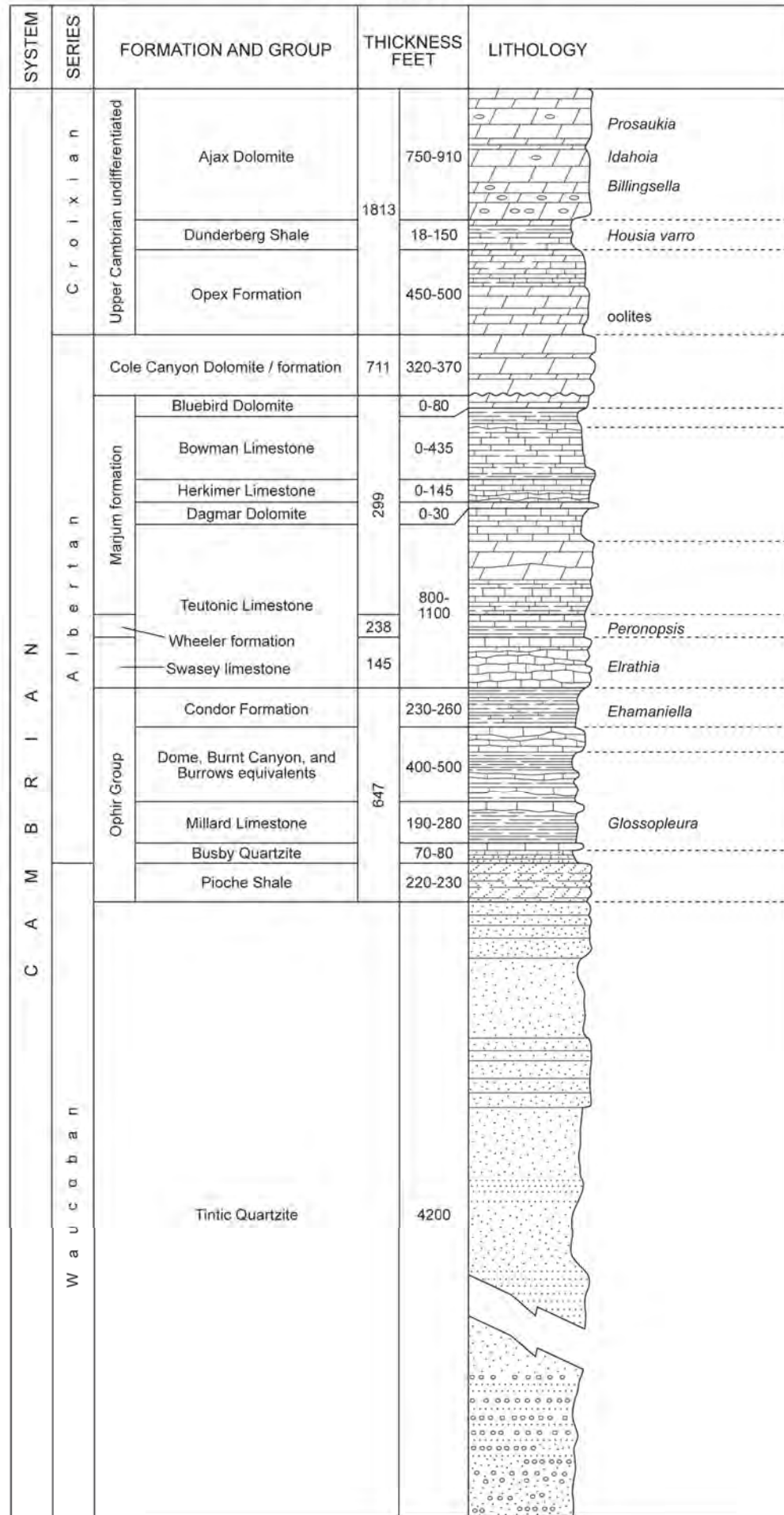

STANSBURY MOUNTAINS (Clark and Kirby, 2009)
Western Utah nomenclature

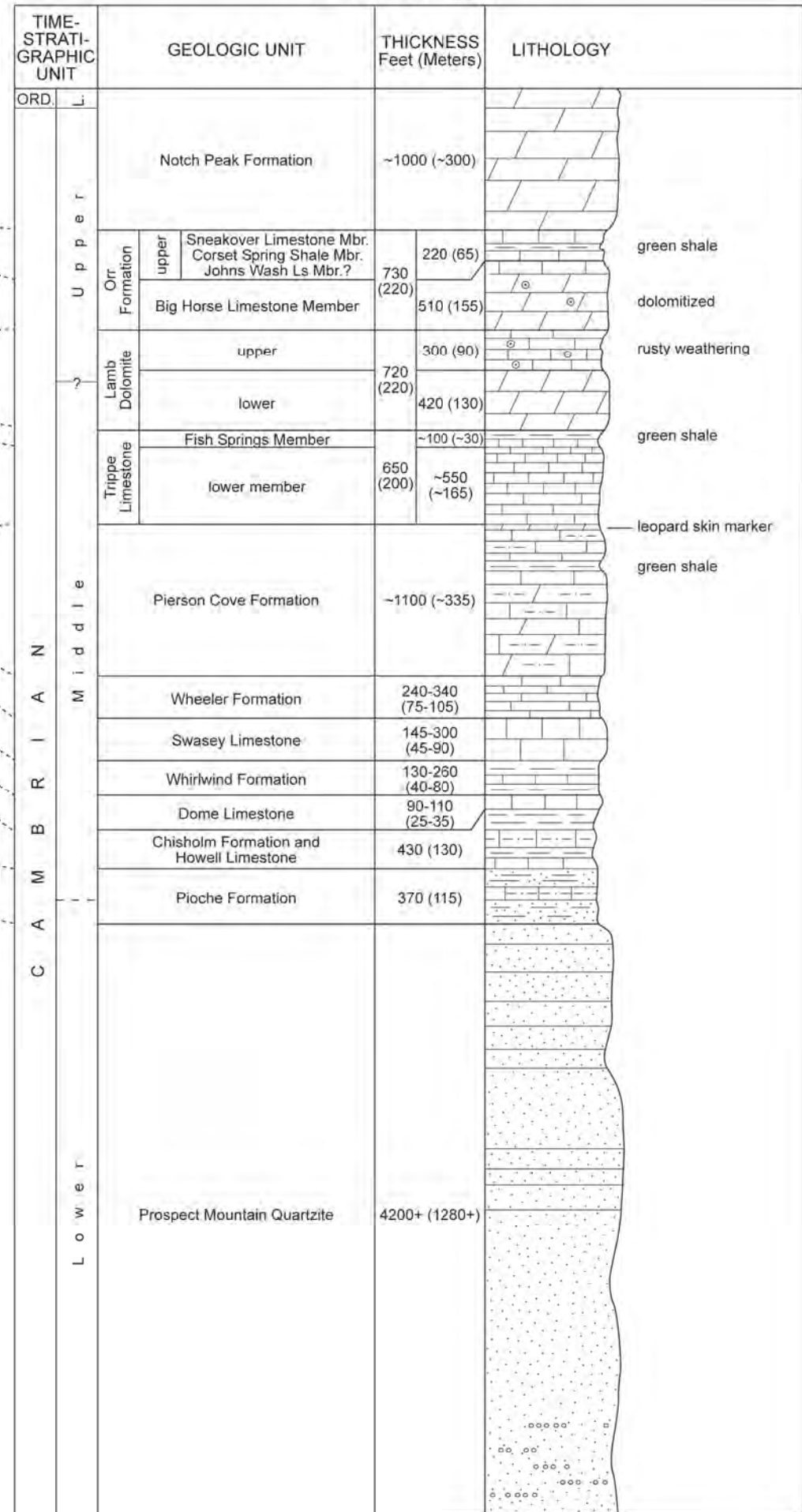

Table 1. Ages and elevations of major shorelines of Lake Bonneville in part of the Rush Valley 30' x 60' quadrangle.

Lake Cycle and Phase	Shoreline (map symbol)	Age		Government Creek Basin	Skull Valley	Southern Tooele Valley	Rush Valley	Cedar Valley	Goshen Valley
		radiocarbon years B.P.	calendar-calibrated years B.P.	Elevation feet (meters)	Elevation feet (meters)	Elevation feet (meters)	Elevation feet (meters)	Elevation feet (meters)	Elevation feet (meters)
Lake Bonneville									
Transgressive Phase	Stansbury (S)	22,000-20,000 ¹	27,000-24,000 ²	4460 (1360)	4470 (1363)	not in map area	not present	not present	not present
	Bonneville (B)	15,000-14,500 ³	18,300 ⁴ -17,400 ⁵	5240-5260 (1598-1604)	5260-5280 (1604-1610)	5235-5245 (1596-1599)	5185-5260 (1580-1603)	5165-5180 (1575-1579)	5125-5150 (1563-1570)
flood									
Regressive Phase	Provo (P)	14,500-12,000 ⁶	17,400 ⁵ -14,400 ⁷	4850-4880 (1479-1488)	4800-4880 (1463-1488)	4845-4880 (1477-1487)	see below	4800 (1463)	not in map area
	Gilbert (G)	10,500-10,000 ⁸	12,500-11,500 ⁹	not present	not in map area	not in map area	see below	not present	not present
	Shambip (Sh) ¹⁰	no data	no data				5045-5060 (1538-1542)		
	Smelter Knolls (SK) ¹⁰	no data	no data				5010 (1527)		

¹ Oviatt and others (1990).

² Calendar calibration using Fairbanks and others (2005; <http://www.radiocarbon.ldeo.columbia.edu/research/radcarbcal.htm>).

³ Oviatt and others (1992), Oviatt (1997).

⁴ Oviatt (written communication to Barry Solomon, UGS, 2009), using Stuiver and Reimer (1993) for calibration.

⁵ CRONUS-Earth Project (2005), using Stuiver and others (2005) for calibration.

⁶ Godsey and others (2005) revised the timing of the occupation of the Provo shoreline and subsequent regression; Oviatt and others (1992) and Oviatt (1997) proposed a range from 14,500 to 14,000 ¹⁴C yr B.P. Oviatt and Thompson (2002) summarized many recent changes in the interpretation of the Lake Bonneville radiocarbon chronology.

⁷ Godsey and others (2005), using Stuiver and Reimer (1993) for calibration.

⁸ Oviatt and others (2005).

⁹ Calendar calibration of data in Oviatt and others (2005), using Stuiver and Reimer (1993) and Hughen and others (2004).

¹⁰ Burr and Currey (1988, 1992) reported that regressive-phase shorelines in Rush Valley fluctuated independently from the main body of Lake Bonneville subsequent to construction of the Stockton Bar. They reported these shorelines may be equivalent in age to the Provo and Gilbert.

Table 2. Summary of ash-bed (tephra) data in the Rush Valley 30' x 60' quadrangle.

Sample Number	7.5' Quadrangle	Latitude (N) NAD83	Longitude (W) NAD83	Tephra Name	Age (Ma)	Error (Ma)	Age Type	Comments	Reference
Skull Valley									
TR1-4 (8')	Hickman Knolls	-	-	unknown (SE California tephra?)	~3-4	-	interpolation?	ash analysis by M.E. Perkins	Geomatrix, 2001; Perkins, pers. comm, 2009
ctb-1-80	Hickman Knolls	-	-	unknown	~6?	-	-	ash analysis by M.E. Perkins	Geomatrix, 2001; Perkins, pers. comm, 2009
ctb-5-75	Hickman Knolls	-	-	unknown	~6?	-	-	ash analysis by M.E. Perkins	Geomatrix, 2001; Perkins, pers. comm, 2009
ctb-8-70	Hickman Knolls	-	-	unknown	~6?	-	-	ash analysis by M.E. Perkins	Geomatrix, 2001; Perkins, pers. comm, 2009
ctb-1-155	Hickman Knolls	-	-	Walcott	6.31	0.04	correlation	ash analysis by M.E. Perkins	Geomatrix, 2001; Perkins, pers. comm, 2009
A-1 (85')	Hickman Knolls	-	-	Walcott	6.4	0.2	correlation	ash analysis by W.P. Nash	SWEC, 1997
A-1 (90')	Hickman Knolls	-	-	Walcott	6.4	0.2	correlation	ash analysis by W.P. Nash	SWEC, 1997
TR1-1 (8')	Hickman Knolls	-	-	unknown	~4 to 15	-	-	ash analysis by M.E. Perkins	Geomatrix, 2001; Perkins, pers. comm, 2009
TR1-2 (10')	Hickman Knolls	-	-	unknown	~4 to 15	-	-	ash analysis by M.E. Perkins	Geomatrix, 2001; Perkins, pers. comm, 2009
TR1-3 (5')	Hickman Knolls	-	-	unknown	~4 to 15	-	-	ash analysis by M.E. Perkins	Geomatrix, 2001; Perkins, pers. comm, 2009
South Willow Canyon									
sb87-11	Deseret Peak East	40.497440°	112.562570°	Cougar Point Tuff unit XIII	10.94	0.03	correlation - Ar/Ar	in steep, narrow gully	Perkins, unpub data
Rush Valley									
rv88-18	Faust	40.176270°	112.392160°	Blacktail Creek	6.66	0.03	correlation - Ar/Ar	exposed on east side of UP tracks	Perkins and others, 1998; Perkins, unpub data
rv92-69	Vernon NE	40.167920°	112.319670°	Blacktail Creek	6.66	0.03	correlation - Ar/Ar		Perkins, unpub data
rv93-553	Vernon NE	40.180940°	112.372580°	Blacktail Creek	6.66	0.03	correlation - Ar/Ar		Perkins, unpub data
rv88-2	Vernon NE	40.179060°	112.372000°	Cub River	7.05	0.03	interpolation		Perkins and others, 1998; Perkins, unpub data
rv88-15a	Faust	40.176267°	112.390580°	Faust	7.54	0.04	correlation - Ar/Ar	a number of short adits into this tephra	Perkins and others, 1998; Perkins, unpub data
rv88-12b	Faust	40.179310°	112.386932°	Rush Valley	8.39	0.24	correlation - Pb/U	very thick tephra mined for light weight aggregate	Perkins and others, 1998; Perkins, unpub data
rv89-11	Faust	40.176381°	112.384817°	Inkom	8.59	0.18	interpolation		Perkins and others, 1998; Perkins, unpub data
rv89-240	Vernon NE	40.169460°	112.371400°	McMillan Cr. Tuff unit 1	9.22	0.04	correlation - Ar/Ar	Hill 5333 section; location approximate sample collected at/near this location;	Perkins, unpub data
rv88-10	Faust	40.178043°	112.380614°	Schmidt Ranch?	9.3	0.17	interpolation	possible correlative of Great Plains tephra	Perkins and others, 1998; Perkins, unpub data
rv88-5	Vernon NE	40.175920°	112.375670°	Section 26	9.61	0.15	interpolation		Perkins and others, 1998; Perkins, unpub data
rv88-0	Vernon NE	40.177010°	112.373170°	-	9.82	0.23	interpolation	fault between this sample and rv88-2	Perkins, unpub data
Tickville Gulch									
TS9903-2	Tickville Spring	40°25'29.2"	112°02'09.0"	Walcott	6.4	0.2	correlation	ash analysis by M.E. Perkins	Biek and others, 2005
TS101904-1	Tickville Spring	40°25'18.0"	112°01'55.0"	Walcott	6.4	0.2	correlation	ash analysis by M.E. Perkins	Biek and others, 2005

Notes:

Skull Valley area samples were from the subsurface, depths in feet indicated in parentheses; location coordinates were not presented, samples are shown on maps in references.

Age type (correlation) are based on correlation to the database of analyses/stratigraphic data/age dates for late Cenozoic vitric tephra layers in the Western U.S. assembled by M.E. Perkins and several colleagues at the University of Utah, Dept. of Geology and Geophysics. Some of the key tephra layers in this database are described in Perkins and others (1995, 1998). Refer to Perkins and others (1995) for procedures on sample preparation and analyses.

Age type (correlation - Ar/Ar, - Pb/U) are based on correlation to tephra with isotopic age measurement. All Ar/Ar ages are relative to an age of 28.02 Ma for the Fish Canyon Rhyolite sanidine Ar monitor.

Age type (interpolation) are interpolated age estimates relative to isotopic ages.

Table 3. Selected major- and trace-element whole-rock analyses for the Rush Valley 30' x 60' Quadrangle.

Sample Number	Map Unit	Rock Name	7.5' Quadrangle	Location Data	Location Data	SiO ₂	Al ₂ O ₃	Fe ₂ O ₃	CaO	MgO	Na ₂ O	K ₂ O	Cr ₂ O ₃	TiO ₂	MnO	P ₂ O ₅
<i>Data from Cedar Mountains and DPG Area by Clark and others (2008) and Clark (2008).</i>																
				Latitude (N) NAD27	Longitude (W) NAD27											
D-47	Trr	Rhyolite	Tabbys Peak	40°26'18.0"	112°56'57.2"	68.97	14.05	1.31	2.04	0.37	2.74	3.98	<0.01	0.1	0.03	0.03
D-48	Trr	Rhyolite	Tabbys Peak	40°25'10.8"	112°58'38.3"	67.55	14.38	2.96	2.61	0.89	3.18	4.45	<0.01	0.36	0.03	0.14
D-49	Trr	Rhyolite	Tabbys Peak	40°22'38.1"	112°57'38.9"	68.18	14.87	2.12	2.2	1.02	3.18	3.78	<0.01	0.43	0.01	0.17
D-51	Trr	Rhyolite	Tabbys Peak	40°23'11.7"	112°57'13.1"	75.73	14.96	0.61	0.71	0.16	0.06	0.05	<0.01	0.45	<0.01	0.14
D-10	Tac	Andesite	Tabbys Peak SW	40°21'33.4"	112°59'42.4"	59.97	16.24	6.19	4.83	1.78	2.95	3.62	<0.01	0.84	0.08	0.25
D-12	Tac	Andesite	Tabbys Peak SW	40°20'12.9"	112°58'21.1"	59	16.41	7.34	6.22	3.86	2.66	2.24	0.01	0.81	0.11	0.19
D-15	Tac	Dacite	Tabbys Peak SW	40°20'33.7"	112°58'07.7"	62.68	15.82	5.65	4.27	1.68	2.81	3.87	<0.01	0.76	0.07	0.25
D-17	Tac	Andesite	Tabbys Peak SW	40°18'39.6"	112°56'36.3"	60.15	15.85	6.89	5.05	2.96	2.73	3.62	0.01	0.94	0.1	0.29
D-19	Tac	Dacite	Tabbys Peak SW	40°19'01.9"	112°56'32.6"	63.54	15.71	5.77	4	1.88	2.85	3.69	0.01	0.68	0.06	0.22
D-20	Tac	Andesite	Tabbys Peak SW	40°19'05.1"	112°56'26.7"	61.8	16.34	5.8	4.44	2.09	2.82	3.8	0.01	0.71	0.08	0.24
D-21	Tac	Dacite	Tabbys Peak SW	40°19'06.1"	112°56'23.8"	61.21	16.03	5.69	4.26	1.71	3	3.64	<0.01	0.67	0.06	0.23
D-25	Tac	Andesite	Tabbys Peak SW	40°16'13.7"	112°56'23.9"	61.01	15.33	6.25	4.56	2.79	2.78	3.72	0.01	0.75	0.09	0.24
D-31	Tac	Andesite	Tabbys Peak SW	40°16'11.5"	112°52'39.7"	60.04	14.74	6.5	4.89	3.44	2.55	3.47	0.01	0.76	0.09	0.25
D-32	Tac	Andesite	Tabbys Peak SW	40°16'06.8"	112°53'04.2"	58.71	15.13	7.55	5.36	4.21	2.24	3.43	0.02	0.99	0.11	0.29
D-37	Tac	Dacite	Camels Back Ridge NE	40°13'40.9"	112°48'36.5"	63.03	14.6	6.32	4.11	3.1	2.83	3.46	0.01	0.64	0.08	0.21
D-38	Tac	Andesite	Tabbys Peak SE	40°15'04.8"	112°46'02.3"	60.56	14.88	7.2	4.63	3.31	2.52	3.59	0.02	0.85	0.08	0.26
D-46	Tac	Andesite	Tabbys Peak	40°27'58.0"	112°54'25.1"	61.24	16.09	5.63	4.67	2.64	3.32	2.75	0.01	0.88	0.07	0.24
D-40	Taci	Andesite	Tabbys Peak	40°27'47.7"	112°59'13.8"	59.96	16.84	6.8	5.89	3.25	2.84	2.34	<0.01	0.77	0.1	0.18
FM083105-1	Tdi	Dacite	Camels Back Ridge NE	40°12'08"	112°50'16"	67.9	15.29	3.62	2.69	1.44	3.55	3.6	<0.01	0.5	0.05	0.18
D-4	Tdi	Dacite	Tabbys Peak SW	40°19'17.9"	112°54'01.1"	63.46	14.65	3.7	3.51	1.95	3.34	3.73	0.01	0.53	0.05	0.18
<i>Data from Stansbury Mountains, South Mountain, and Oquirrh Mountains (this study)</i>																
				UTM Easting NAD27	UTM Northing NAD27											
RV-1	Tvs	Lalite	Deseret Peak East	366962	4483890	60.02	16.2	6.58	4.78	1.82	3.13	3.95	<0.01	0.79	0.06	0.36
RV-13	Tbi	Basalt	South Mountain	377877	4480341	49.55	13.36	9.29	8.54	10.91	2.58	2.3	0.11	1.24	0.15	0.519
RV-24	Tri	Rhyolite	Mercur	396473	4462674	73.1	13.06	0.66	0.87	0.47	0.82	7.38	<0.01	0.1	0.03	0.025
RV-25	Tpqmi	Granodiorite	Mercur	395695	4466373	63.7	15.79	4.15	3.77	1.75	3.63	3.24	0.07	0.53	0.08	0.29
RV-26	Tpqmi	Granodiorite	Mercur	395980	4466718	64.37	15.48	4.24	3.14	1.49	3.41	3.35	<0.01	0.6	0.07	0.277
RV-30	Tmi	Monzonite	Stockton	387157	4478428	58.77	14.8	6.31	5.52	4.36	3.14	3.9	0.02	0.84	0.09	0.352
<i>Data from Vernon Hills area by Kirby (2010a, 2010b) and this study.</i>																
				UTM Easting NAD83	UTM Northing NAD83											
164	-	Rhyolite	Sabie Mountain	382879	4428112	71.15	12.71	2.1	0.61	0.33	0.95	8.91	0.01	0.28	0.03	0.116
216	Trv	Rhyolite	Lofgreen	382688	4428566	71.54	12.46	1.9	2.19	0.41	2.28	5.37	0.02	0.28	0.03	0.073
219	Trv	Rhyolite	Vernon	381617	4434991	72.97	13.38	2.12	1.67	0.44	3.27	4.34	0.01	0.28	0.08	0.067
220	Tbav	Basaltic andesite	Vernon	381529	4434651	53.99	14.65	8.46	6.72	7.36	2.62	2.06	0.08	1.2	0.13	0.374
872	Trv	Rhyolite	Vernon	382096	4430373	72.11	13.06	1.92	0.5	0.29	0.21	10.6	<0.01	0.27	0.02	0.092
873	Trv	Rhyolite	Vernon	381537	4430359	73.11	13.08	2.28	1.16	0.48	2.15	5.75	<0.01	0.27	0.04	0.086
874	Trv	Rhyolite	Vernon	381063	4430389	76.25	11.16	1.72	0.66	0.4	1.7	6.19	<0.01	0.24	0.03	0.079
879	Trv	Rhyolite	Vernon	380034	4434853	70.14	14.39	2.09	2.05	0.75	3.1	4.27	<0.01	0.26	0.07	0.07
881	Trv	Rhyolite	Vernon	380159	4432918	70.05	13.37	1.85	2.35	0.7	2.2	3.6	<0.01	0.24	0.07	0.06
905	Tdv	Dacite	Lofgreen	384211	4437458	62.83	14.55	5.2	4.85	1.78	2.19	4.7	<0.01	0.67	0.07	0.206
910	Tdv	Dacite	Lofgreen	384293	4439627	72.76	14.78	2.56	1.56	0.25	0.1	0.58	<0.01	0.41	0.01	0.092
920	Tdv	Trachydacite	Lofgreen	382814	4437572	59.93	14.75	5.04	4.98	1.83	1.83	6.35	<0.01	0.67	0.11	0.232

Notes:

Major oxides reported in weight percent by x-ray fluorescence (XRF); minor and trace elements reported in ppm by inductively coupled plasma-mass spectrometry (ICP-MS).

Analyses for UGS performed by ALS Chemex, Sparks and Reno, NV.

Rock names from total alkali-silica diagram of LeBas and others (1986) or Middlemost (1994).

LOI is loss on ignition.

For additional geochemical data see Biek and others (2005), Biek (2006b).

SrO	BaO	LOI	Total	Ag	Ba	Ce	Co	Cr	Cs	Cu	Dy	Er	Eu	Ga	Gd	Hf	Ho	La	Lu	Mo
0.04	0.16	4.57	98.38	<1	1490	72.2	0.6	<10	3	<5	2.47	1.63	1.06	17.6	3.76	4.2	0.49	41.6	0.26	<2
0.05	0.16	1.84	98.6	<1	1305	45.7	6.5	40	4.42	16	2.43	1.49	0.95	16.2	3.26	4.3	0.48	25.9	0.21	<2
0.06	0.18	2.25	98.46	<1	1625	88.9	4.7	30	3.17	10	2.04	1.12	1.23	21.2	4.18	5.7	0.35	50.4	0.14	<2
0.01	0.08	6.43	99.37	<1	678	89.6	2.1	30	1.29	12	1.88	1.01	1.08	20.7	4.09	5.5	0.33	51	0.13	<2
0.06	0.15	2.06	99.01	<1	1245	79.9	12.9	20	1.59	10	4.61	2.54	1.71	21.1	5.96	5.8	0.87	45	0.37	<2
0.03	0.1	1.02	100	<1	863	81.4	20.3	130	3.08	18	5.34	3.15	1.65	20.3	6.26	6.3	1.06	43.2	0.45	3
0.05	0.15	1.54	99.6	<1	1325	86.7	14.7	50	4.49	12	3.79	2.68	1.44	22.6	5.73	6.7	0.88	48.8	0.36	2
0.05	0.16	1.18	99.98	<1	1395	92.2	23.3	140	4.9	20	4.54	2.98	1.67	24.2	6.66	7.3	0.97	49.2	0.39	4
0.05	0.15	1.49	100.1	<1	1350	88.4	14.2	70	4.7	18	3.85	2.71	1.48	23	5.84	6.7	0.89	50.2	0.38	2
0.05	0.16	1.49	99.83	<1	1350	86.9	13.2	70	5.51	8	3.64	2.56	1.41	21.7	5.6	6.2	0.85	47.7	0.36	3
0.06	0.16	1.92	98.64	<1	1420	85.8	13.3	60	4.11	17	3.54	2.46	1.46	21.5	5.63	6.3	0.82	48.9	0.34	2
0.05	0.15	1.69	99.42	<1	1255	87.9	16.4	130	3.9	22	3.91	2.79	1.48	19.8	5.84	6.6	0.91	47.6	0.38	2
0.05	0.16	2.38	99.33	<1	1245	85.5	20.7	170	4.7	32	3.72	2.73	1.39	20.6	6.03	6.6	0.9	47.8	0.37	2
0.05	0.13	1.2	99.42	<1	1100	88.3	27.1	220	3.82	32	4.35	3.03	1.58	20.7	6.48	6.8	1.01	46.8	0.41	3
0.05	0.18	1.25	99.87	<1	1375	78.1	20	140	4.17	30	2.56	2.06	1.25	20	4.9	5.5	0.69	44.4	0.25	3
0.05	0.15	1.34	99.43	<1	1140	82.1	18.5	160	4.85	25	3.81	2.66	1.45	19.6	5.78	6.1	0.91	44.3	0.32	2
0.05	0.15	2.26	100	<1	1215	120	18.8	100	2.29	27	2.86	1.98	1.49	20.9	6.19	6.9	0.64	66.6	0.21	3
0.04	0.09	0.96	100.05	<1	740	75.1	19.6	40	2.3	16	3.87	2.89	1.34	20.2	5.35	5.7	0.95	41	0.39	2
0.06	0.19	0.91	99.99	<1	1775	108.5	8.7	70	2.5	8	3	1.7	1.5	20	4.9	6	0.6	61.6	0.2	<2
0.07	0.17	3.15	98.5	<1	1505	115	10.6	110	6.3	15	3.43	1.9	1.49	18.7	5.58	5.8	0.6	64.9	0.24	2
0.06	0.16	1.83	99.75	<1	1410	95.1	16.1	60	4.82	19	5.38	3.34	1.86	22.1	7.34	6.7	1.11	50.7	0.47	<2
0.08	0.21	0.75	99.58	<1	1645	109.5	39.3	690	2.27	77	3.52	2.07	2.09	17.7	5.94	3.9	0.74	58.5	0.27	<2
0.02	0.09	2.75	99.38	<1	862	47.7	0.6	<10	4.65	<5	4.15	1.78	0.66	17.5	4.11	3	0.72	25.3	0.21	<2
0.1	0.18	2.56	99.84	<1	1555	114	8.7	20	2.17	11	4.36	2.24	1.7	19.3	6.41	5.2	0.8	61.3	0.3	<2
0.08	0.18	2.03	98.72	<1	1540	118.5	9.4	20	1.43	12	3.86	2.31	1.77	19.4	7.15	5.5	0.72	65.1	0.32	<2
0.09	0.24	0.45	98.88	<1	1935	145	21.6	130	4.68	45	4.19	2.36	2	19.6	8.6	4.2	0.76	79	0.26	2
0.02	0.1	1	98.32	<1	843	68.3	3.9	10	3.43	25	2.42	1.51	0.83	14.7	3.78	3.9	0.49	38.7	0.25	2
0.02	0.09	1.75	98.42	<1	789	66.9	3.6	<10	2.51	26	2.3	1.46	0.78	13.7	3.52	3.8	0.47	37	0.26	<2
0.03	0.08	0.66	99.41	<1	709	69.6	3.1	10	9.32	15	2.71	1.72	0.84	15.3	3.76	3.6	0.56	36.3	0.28	<2
0.07	0.14	2.07	99.94	<1	1055	100.5	36.4	360	4.2	51	4.74	2.61	1.92	18.4	7.38	6.2	0.94	52.2	0.32	<2
0.01	0.06	0.71	99.84	<1	531	38.8	3.5	10	2.49	5	1.21	0.77	0.56	15	1.89	3.2	0.25	23.1	0.14	<2
0.02	0.09	1.19	99.7	<1	769	61.6	3.2	10	4.26	5	1.86	1.26	0.75	15.1	2.82	3.3	0.39	35.5	0.22	<2
0.01	0.11	1.24	99.79	<1	892	56	3.4	10	23.3	5	1.73	1.2	0.73	12.4	2.69	3.1	0.38	35.1	0.21	<2
0.03	0.08	2.53	99.84	<1	699	80.3	2.4	<10	7.53	<5	2.73	1.94	1.03	15.1	3.98	3.7	0.6	43.4	0.3	2
0.08	0.09	4.93	99.59	<1	728	68.9	2.6	10	7.27	<5	2.42	1.69	0.93	13.9	3.33	3.3	0.56	36.2	0.28	<2
0.06	0.08	2.12	99.31	<1	800	84.5	12.2	20	3.52	8	3.32	2.05	1.52	17.8	5.04	4.8	0.71	44.6	0.28	<2
0.04	<0.01	6.78	99.92	<1	117.5	97	1.8	20	12.85	5	6.86	4.6	1.82	17	7.44	4.7	1.62	48.2	0.6	<2
0.05	0.1	2.71	98.57	<1	823	78.2	12.2	20	0.64	6	3.53	2.29	1.42	16.3	4.89	4.3	0.78	40.4	0.35	<2

	Nb	Nd	Ni	Pb	Pr	Rb	Sm	Sr	Sr	Ta	Tb	Th	Tl	Tm	U	V	W	Y	Yb	Zn	Zr
	14	23.9	<5	28	7.26	130	3.83	1	304	1	0.48	17.2	<0.5	0.23	3.72	8	5	14.7	1.73	39	130
	11.4	18.9	7	25	5.18	135.5	3.52	1	409	0.8	0.46	12.7	0.5	0.2	3.1	45	1	13.9	1.48	41	142
	18.1	30.9	9	32	9.12	161.5	4.63	2	568	1.5	0.48	22.8	0.6	0.14	6.04	57	3	9.7	1.03	40	192
	17.4	30.9	5	12	9.26	3.9	4.61	2	26.2	1.4	0.44	23.5	<0.5	0.12	9.82	42	6	9.2	0.95	18	184
	13.5	34.4	<5	19	9.55	120	6.18	1	515	0.9	0.84	13.95	<0.5	0.37	2.95	135	2	23.8	2.44	82	214
	17.2	34.1	14	17	9.55	80.2	6.19	2	300	1.2	0.91	11.6	<0.5	0.46	2.89	154	2	27.5	2.85	85	232
	20.8	36.5	11	26	10.15	152	6.53	3	473	1.7	0.83	19.4	0.5	0.39	5.74	133	5	27.6	2.53	73	259
	20.2	40.5	18	26	10.9	143.5	7.18	3	545	1.5	0.93	17.2	0.5	0.45	4.61	188	4	30.3	2.77	96	271
	19.7	36.5	15	29	10.15	145	6.55	3	464	1.7	0.85	19.95	0.6	0.4	5.77	113	5	27.5	2.49	74	261
	17.1	35.4	7	27	9.84	135.5	6.21	3	490	1.6	0.82	18	0.5	0.38	4.83	122	29	25.5	2.45	74	240
	17.1	35.1	15	28	9.81	122.5	6.25	2	524	1.3	0.78	18.05	<0.5	0.37	4.74	104	5	25.7	2.46	75	236
	19.2	37	19	25	10.05	136	6.39	3	440	1.4	0.84	17.75	<0.5	0.43	4.52	127	4	27.9	2.65	70	257
	19.1	36.5	35	24	10.05	135	6.37	3	479	1.4	0.87	18	<0.5	0.41	4.77	144	3	28.7	2.61	78	257
	18.6	38.2	38	21	10.35	121	6.93	2	466	1.2	0.93	16.6	<0.5	0.44	3.73	183	3	31.8	2.91	84	265
	14.1	32.1	32	25	8.79	133	5.49	2	438	1	0.68	19.4	0.5	0.29	4.72	117	4	21.4	2.01	68	222
	17.3	36	22	24	9.59	138	6.44	2	460	1.2	0.83	16.35	0.5	0.37	4.18	165	3	27.4	2.54	72	246
	23.7	45.7	44	25	13.25	105	6.99	2	482	1.6	0.78	28.1	<0.5	0.26	5.04	100	3	19.8	1.6	82	266
	20.1	30.9	11	19	8.51	84.9	5.45	3	347	1.3	0.81	14.35	<0.5	0.41	3.65	152	3	28.2	2.69	74	219
	15	37.3	14	49	11.2	127.5	5.7	2	634	1.1	0.6	21	<0.5	0.2	3.4	67	1	16.7	1.5	59	198
	18	42	31	33	12.6	144	6.36	2	574	1.8	0.68	26.6	<0.5	0.24	9.13	67	2	15.7	1.62	63	193
	13.7	42	15	29	11.25	139	7.72	2	583	0.8	0.97	16.4	<0.5	0.46	3.86	139	1	31.4	3.17	107	229
	25.4	43.7	205	13	12.85	56.5	6.82	1	626	1.3	0.8	11	<0.5	0.27	2.41	158	1	16.8	1.59	89	149
	19.3	17.6	<5	24	5.3	256	3.55	2	121.5	1.8	0.76	20.8	0.7	0.25	5.96	9	2	23.2	1.48	17	74
	12.8	43.3	9	26	12.55	94.3	6.98	1	871	0.9	0.87	14.2	<0.5	0.3	2.87	64	1	23	1.98	63	190
	13	46.7	9	24	13.45	91.7	7.13	1	687	0.9	0.83	14.5	<0.5	0.26	3.28	64	2	19.4	2.05	55	195
	12.8	55.5	46	47	16.45	141.5	8.75	1	726	0.9	1	30.3	<0.5	0.28	5.49	124	2	19.5	1.89	78	141
	14.6	25.5	<5	34	6.98	259	4.09	1	116.5	1.2	0.48	21.9	0.9	0.22	5.06	22	7	15.1	1.55	31	128
	14.4	24.2	<5	31	6.65	201	3.72	1	234	1.3	0.43	21.8	0.8	0.23	4.65	15	4	14.9	1.63	26	118
	16.1	26.8	<5	32	7.15	174.5	4.43	2	251	1.4	0.5	20.9	0.9	0.26	5.82	15	3	17.1	1.76	29	110
	16.8	45.6	118	16	11.2	84	8.23	2	662	0.9	0.95	10.65	1.1	0.34	1.94	113	2	25.1	2.13	80	237
	13.1	14.5	<5	12	4.75	149	2.19	1	38.3	1.3	0.26	23.1	<0.5	0.11	4.41	19	6	6.1	0.76	34	108
	14.3	20.1	<5	24	6.56	167.5	2.97	1	175	1.4	0.38	25.3	0.5	0.18	4.82	26	6	10.5	1.21	46	116
	11.8	20.3	<5	19	6.59	342	3.05	1	99.2	1.2	0.38	20.7	4.1	0.18	4.62	63	21	10	1.15	30	111
	15.8	27.5	<5	23	8.78	145	4.16	2	249	1.5	0.57	21.1	0.5	0.28	6.04	20	4	16.2	1.76	41	122
	14.2	23.8	<5	22	7.49	78	3.8	1	543	1.3	0.49	18.45	<0.5	0.26	2.67	21	15	14.6	1.63	35	113
	11.9	34	7	18	10	138.5	5.75	1	473	1	0.75	17.35	<0.5	0.29	3.6	102	2	17.5	1.64	67	178
	17.1	40.7	9	24	11.65	35.6	8.21	2	234	1.2	1.29	14.7	<0.5	0.64	3.02	42	9	41.7	3.7	35	151
	10.9	32.1	6	19	9.22	158	5.48	1	353	1	0.72	16.4	0.5	0.32	3.05	84	2	20.1	2.01	66	159

Table 4. Summary of $^{40}\text{Ar}/^{39}\text{Ar}$ and K-Ar age analyses from the Rush Valley 30' x 60' quadrangle.

$^{40}\text{Ar}/^{39}\text{Ar}$ Analyses											
Sample Number	Map Unit	Rock Name	7.5' Quadrangle	Location Data		Age (Ma)	Material Dated	Laboratory	Comments	Reference	
				Latitude (N) NAD27	Longitude (W) NAD27						
TS102103-5	Tdi	Dacite	Tickville Spring	40°25'05.7"	112°03'57.6"	32.05 ± 0.13	biotite	NMGRL	furnace step-heat, somewhat disturbed	Biek and others, 2005; NMGR and UGS, 2006	
Tick 28	Tvib	Dacite	Tickville Spring	-	-	32.12 ± 0.14	plagioclase	Berkeley	plateau age	Deino and Keith, 1997	
TS33104-7	Tvfa	Basaltic andesite	Tickville Spring	40°25'03.0"	112°03'59.8"	32.86 ± 0.48	groundmass concentrate	NMGRL	furnace step-heat, disturbed	Biek and others, 2005; NMGR and UGS, 2006	
TS33104-4	Tri	Rhyolite	Tickville Spring	40°29'44.1"	112°05'05.7"	35.49 ± 0.13	sanidine	NMGRL	laser total fusion	Biek and others, 2005; NMGR and UGS, 2006	
TS32904-3	Tai	Andesite	Tickville Spring	40°28'26.5"	112°04'00.2"	36.26 ± 0.18	biotite	NMGRL	furnace step-heat	Biek and others, 2005; NMGR and UGS, 2006	
Tick 43	Tvfo	Minette	Tickville Spring	40°26'48"	112°06'30"	37.82 ± 0.14	whole rock	Berkeley	plateau age	Deino and Keith, 1997	
Tick-113	Tvlo	waterlain tuff	Tickville Spring	40°26'42.500"	112°06'4.051"	38.68 ± 0.13	sanidine	Berkeley	plateau age	Mauchan, 2001	
Bing-6	Tli	Latite	Tickville Spring	40°29'42"	112°07'24"	38.84 ± 0.19	plagioclase	Berkeley	plateau age	Deino and Keith, 1997	
D-17	Tac	Andesite	Tabbys Peak SW	40°18'39.6"	112°56'36.3"	39.17 ± 0.47	groundmass concentrate	NMGRL	furnace step-heat	Clark and others, 2008; UGS and NMGR, 2009b	
Tick 23	Tvlo	Latite clast	Tickville Spring	40°28'47"	112°07'11"	39.18 ± 0.11	biotite	Berkeley	plateau age	Deino and Keith, 1997	
FM083105-1	Tdi	Dacite	Camels Back Ridge NE	40°12'08"	112°50'16"	39.56 ± 0.10	biotite	NMGRL	integrated age, low K ₂ O%	Clark and others, 2008; UGS and NMGR, 2009a	
D-4	Tdi	Dacite	Tabbys Peak SW	40°19'17.9"	112°54'01.1"	38.89 ± 0.10	sanidine	NMGRL	laser total fusion	Clark and others, 2008; UGS and NMGR, 2009b	
D-40	Taci	Andesite	Tabbys Peak	40°27'47.7"	112°59'13.8"	40.61 ± 0.78	groundmass concentrate	NMGRL	furnace step-heat	Clark and others, 2008; UGS and NMGR, 2009b	
FM083105-1	Tdi	Dacite	Camels Back Ridge NE	40°12'08"	112°50'16"	40.95 ± 0.32	hornblende	NMGRL	step-heating, plateau age	Clark and others, 2008; UGS and NMGR, 2009a	
				UTM Easting NAD27	UTM Northing NAD27						
RV-24	Tri	Rhyolite	Mercur	396473	4482674	pending		UNLV			
RV-25	Tpami	Granodiorite	Mercur	395695	4466373	pending		UNLV			
RV-30	Tmi	Granodiorite	Stockton	387157	4478428	pending		UNLV			
				UTM Easting NAD83	UTM Northing NAD83						
396	Tsl	Tephra	Lofgreen	386444	4434256	pending		UNLV			
411	TKs	Tephra	Lofgreen	382096	4448888	pending		UNLV			
1139	Tsl	Tephra	Vernon NE	383128	4446338	pending		UNLV			
873	Trv	Rhyolite	Vernon	381537	4430359	pending		UNLV			
879	Trv	Rhyolite	Vernon	380034	4434853	pending		UNLV			
920	Tdv	Trachydacite	Lofgreen	382814	4437572	pending		UNLV			
K-Ar Analyses				Latitude (N) NAD27		Longitude (W) NAD27					
74-KA-1	Tb	Olivine basalt	Goshen Pass	40°09'15"	112°00'35"	21.4 ± 2.5	whole rock		Goshen Pass area	Moore and McKee, 1983	
9	Tvbs	Hornblende latite tuff-breccia	Tickville Spring	40°28'00"	112°02'24"	30.7 ± 0.9	biotite		W Traverse Mtns - South Mountain	Moore, 1973	
11	Trf	Biotite rhyolite vitrophyre	Tickville Spring	40°25'12"	112°01'12"	31.2 ± 0.9	biotite		W Traverse Mtns - Tickville Gulch rhyolite flow	Moore, 1973	
12	Tri	Fine-grained biotite rhyolite	Mercur	40°18'24"	112°12'12"	31.6 ± 0.9	biotite		Oquirrh Mtns - Mercur district, Eagle Hill rhyolite plug	Moore, 1973	
10	Tri	Biotite rhyolite vitrophyre	Tickville Spring	40°29'48"	112°05'00"	33.0 ± 1.0	biotite		W Traverse Mtns - Shaggy Peak plug	Moore, 1973	
WT-41	Tpami	Biotite granodiorite porphyry	Mercur	40°20'45"	112°13'20"	36.7 ± 0.5	biotite		Oquirrh Mtns - Porphyry Hill at Ophir	Moore and McKee, 1983	
6	Tli	Quartz latite porphyry dike	Low Peak	40°29'36"	112°12'24"	37.1 ± 1.1	biotite		Oquirrh Mtns - Middle Canyon area	Moore, 1973	
7	Tmi	Monzonite porphyry stock	Stockton	40°26'48"	112°19'48"	38.0 ± 1.1	biotite		Oquirrh Mtns - Stockton District, Calumet Mine area	Moore, 1973	
74-KA-2	Trv	Biotite-hornblende rhyolite	Vernon	40°18'15"	112°12'00"	38.0 ± 0.5	biotite		Vernon Hills	Moore and McKee, 1983	
69-TS-32	Tvfo	Nepheline basalt	Tickville Spring	40°25'40"	112°05'45"	38.5 ± 0.3	whole rock		Oquirrh Mtns - South of Bingham mine	Moore and McKee, 1983	
5	Tqi	Quartz monzonite porphyry sill	Stockton	40°30'00"	112°19'00"	38.8 ± 1.1	biotite		Oquirrh Mtns - Seikirk Canyon area	Moore, 1973	
69-SM-2	Tbi	Nepheline basalt	South Mountain	40°27'55"	112°26'30"	40.1 ± 0.5	whole rock		South Mountain dike	Moore and McKee, 1983	

Notes:
 NMGR is New Mexico Geochronology Research Laboratory, Socorro, New Mexico.
 UNLV is University of Nevada, Las Vegas.
 Selected Ar/Ar analyses are plotted on the geologic map.

Table 5. Fossil identifications and ages from Rush Valley 30' x 60' quadrangle.

Data from southern Cedar Mountains by Clark and others (2008)

Sample No.	Map Unit	Rock Type	7.5' Quadrangle	Location Data Latitude (N) NAD27	Location Data Longitude (W) NAD27	Fossil Type	Fauna	Preservation & Abrasion	Calcareous Algae Present	Age
D-69	Pofc	biomicrite; wackestone	Tabbys Peak	40°27'48.0"	112°59'49.5"	fusulinid	<i>Triticites</i> cf. <i>T. meeki</i>	Good	None	early Wolfcampian
D-75	Pofc	biomicrite; mudstone	Tabbys Peak	40°28'10.9"	112°59'46.9"	fusulinid	<i>Triticites</i> cf. <i>T. meeki</i>	Fair	None	early Wolfcampian
D-76	IPobm	biomicrite; wackestone	Tabbys Peak	40°29'53.8"	112°58'41.1"	fusulinid	<i>Triticites</i>	Fair	None	Virgilian
D-68	IPobm	biomicrite; wackestone	Tabbys Peak	40°23'37.1"	112°59'45.3"	fusulinid	<i>Triticites</i>	Fair	None	Virgilian
D-52	IPobm	biomicrite; wackestone	Tabbys Peak SW	40°21'18.4"	112°59'14.5"	fusulinid	<i>Pseudofusulinella</i> , <i>Triticites</i>	Fair	None	early Virgilian
D-57	IPobm	biopartite; packstone	Tabbys Peak SW	40°19'31.0"	112°59'13.0"	fusulinid	<i>Triticites cullamensis</i>	Good	None	early Virgilian
D-71	IPobm	biomicrite; mudstone	Tabbys Peak	40°23'05.6"	112°59'05.3"	fusulinid	<i>Triticites</i>	Good	None	Missourian
D-78	IPobm	biomicrite; wackestone	Tabbys Peak SW	40°20'04.3"	112°58'34.9"	fusulinid	<i>Triticites</i>	Fair	None	Missourian
D-70	IPobp	biomicrite; wackestone	Tabbys Peak	40°23'08.4"	112°58'34.7"	fusulinid	<i>Beedeina</i>	Fair	Fragments	early Desmoinesian
D-50	IPowc	crinoidal packstone	Tabbys Peak	40°22'38.9"	112°57'57.4"	conodont	<i>Adetognathus lautus</i>	-	-	latest Mississippian to early Permian

Note: Fusulinids identified by A.J. Wells (independent).
Conodonts identified by S.R. Ritter (Brigham Young University).

Data from Stansbury Mountains, South Mountain, Oquirrh Mountains (this study)

				UTM Easting NAD27	UTM Northing NAD27					
RV-17	Pofc	biopartite; packstone	Deseret Peak East	359232	4480292	fusulinid	<i>Triticites</i> cf. <i>T. meeki</i>	Good	None	early Wolfcampian
RV-8	Pofc	biopartite; packstone	Deseret Peak East	370302	4476669	fusulinid	<i>Schwagerina</i> , <i>Triticites</i>	Poor	None	early Wolfcampian
RV-11	IPobm	biopartite; packstone	Deseret Peak East	359812	4476473	fusulinid	<i>Triticites</i>	Poor	None	Virgilian
RV-9	IPobm	biomicrite; wackestone	Deseret Peak East	369355	4476355	fusulinid	<i>Triticites</i> cf. <i>T. Cullamensis</i>	Fair	None	Virgilian
RV-2	IPobm	biopartite; packstone	Deseret Peak East	368510	4481907	fusulinid	<i>Triticites</i>	Fair	None	Virgilian
RV-5	IPobm	wackestone	Deseret Peak East	368234	4481041	fusulinid	<i>Triticites</i>	Good	None	Missourian
RV-4	IPobm	biomicrite; wackestone	Deseret Peak East	368084	4481089	fusulinid	<i>Propseudofusulinella</i>	Fair	None	Missourian
RV-6	IPobm	sandstone	Deseret Peak East	367964	4480377	fusulinid	<i>Propseudofusulinella</i>	Good	None	Missourian
RV-14	Pdk	biopartite; grainstone	South Mountain	376615	4480605	fusulinid	<i>Schwagerina</i>	Fair-Poor	None	late-early Wolfcampian
RV-15	Pocp	biomicrite; mudstone	South Mountain	380540	4481840	fusulinid	<i>Triticites</i> , <i>Schwagerina</i>	Poor	None	Wolfcampian
970	IPobm	biomicrite; mudstone	South Mountain	379150	4481088	fusulinid	<i>Triticites</i>	Fair	None	late Missourian to Virgilian
1199	IPobm	calcareous sandstone	South Mountain	378298	4473295	fusulinid	<i>Triticites</i>	Poor	None	Missourian
RV-20	IPobm	calcareous sandstone	South Mountain	380650	4478875	fusulinid	<i>Triticites</i>	Poor	None	early Missourian
RV-18	IPobm	wackestone	South Mountain	381603	4479643	fusulinid	<i>Propseudofusulinella</i>	Good	None	Missourian
RV-28	IPobm	limestone	South Mountain	382228	4479232	conodont	ideognathodids and/or adetognathids	-	-	Pennsylvanian
RV-27	IPobm	limestone	South Mountain	382399	4479227	conodont	ideognathodids and/or adetognathids	-	-	Pennsylvanian
969	IPobp	biomicrite; wackestone	South Mountain	382403	4478628	fusulinid	<i>Fusulina</i>	Poor	None	early Desmoinesian
RV-23	IPobp	calcareous sandstone	Stockton	388761	4480243	fusulinid	<i>Fusulinella</i>	Fair	None	late Atokan
RV-22	IPobp	mudstone	Stockton	359009	4479246	fusulinid	<i>Fusulinella</i>	Poor	None	late Atokan
RV-31	IPowc	limestone	Low Peak	355986	4471439	conodont	ideognathodids and/or adetognathids	-	-	Pennsylvanian

Data from Vernon Hills by Kirby (2010a, b) and this study.

				UTM Easting NAD83	UTM Northing NAD83					
447	IPobm	biomicrite; wackestone	Faust	381793	4443254	fusulinid	<i>Triticites</i> cf. <i>T. cullamensis</i>	Good	None	middle-early Virgilian
720	IPobm	biomicrite; wackestone	Lofgreen	383341	4441425	fusulinid	<i>Pseudofusulinella</i>	Fair	None	late Missourian through Virgilian
726	IPobm	biomicrite; wackestone	Lofgreen	383624	4441112	fusulinid	<i>Pseudofusulinella</i> ; <i>P. cf. forausonianensis</i>	Fair	None	Missourian through earliest Wolfcampian
245	IPobp	biomicrite; mudstone	Lofgreen	383106	4440395	fusulinid	<i>Protusulinella</i>	Good	None	early Atokan
586	IPowc	biomicrite; wackestone	Vernon	382282	4439530	fusulinid	-	Poor	None	Morrowan?

Note: Fusulinids identified by A.J. Wells (independent).
Conodonts identified by S.M. Ritter (Brigham Young University).

Table 5 (continued). Fossil identifications and ages from Rush Valley 30' x 60' quadrangle.

Data from Stansbury Mountains by Jordan (1979a)

Sample Number	Township, Range, Section	7.5' Quadrangle	Fossil Type	Fauna	Map Unit	Age
8f53	4S, 6W, NW1/4 NE1/4 28	Deseret Peak East	fusulinid	<i>Triticites</i> sp., <i>Schwagerina</i> sp.	Pofc	Wolfcampian
8f104B	4S, 6W, SE1/4 SE1/4 17	Deseret Peak East	fusulinid	<i>Pseudofusulinella</i> sp., <i>Triticites</i> sp., <i>Pseudofusulina</i> ?	Pofc	Wolfcampian

Note: Map unit designations from this study.
Fusulinids identified by R. C. Douglas (USGS).

Data from Stansbury Mountains by Armin and Moore (1981)

Locality Number	Sample Number	Township, Range, Section	7.5' Quadrangle	Approx. UTM Easting NAD27	Approx. UTM Northing NAD27	Fossil Type	Fauna	Map Unit	Age
S18	77-AF-46	4S, 6W, 28	Deseret Peak East	370517	4477951	fusulinid	<i>Schwagerina</i> sp.	Pofc	Wolfcampian
S19	77-AF-48	4S, 6W, 29	Deseret Peak East	369432	4478262	fusulinid	<i>Triticites</i> sp., <i>Schwagerina</i> ? sp.	Pofc	Wolfcampian
S14	77-AF-30	4S, 6W, 29	Deseret Peak East	368569	4476962	fusulinid	<i>Pseudofusulinella</i> sp., <i>Triticites</i> sp.	IPobm	Virgilian or Wolfcampian
S22	77-AF-80	5S, 6W, 4	Deseret Peak East	370790	4473903	fusulinid	<i>Pseudofusulinella</i> sp.	IPobm	Late Pennsylvanian or Early Permian
S16	77-AF-40	5S, 6W, 5	Deseret Peak East	369375	4474857	fusulinid	<i>Triticites</i> sp.	IPobm	Late Pennsylvanian or Early Permian
S17	77-AF-42	5S, 6W, 4	Deseret Peak East	370118	4475006	fusulinid	<i>Triticites</i> ? sp.	IPobm	Late Pennsylvanian or Early Permian
S12	77-AF-20	4S, 6W, 20	Deseret Peak East	368545	4479751	fusulinid	<i>Pseudofusulinella</i> sp.	IPobm	Late Pennsylvanian
S23	77-AF-82	5S, 6W, 4	Deseret Peak East	369704	4473721	fusulinid	<i>Triticites</i> ? sp.	IPobm	Late Pennsylvanian
S15	77-AF-36	5S, 6W, 5	Deseret Peak East	368664	4474538	fusulinid	<i>Triticites</i> sp.	IPobm	Late Pennsylvanian
S11	77-AF-19	4S, 6W, 19	Deseret Peak East	367241	4479434	fusulinid	<i>Triticites</i> sp.	IPobp	Late Pennsylvanian
S20	77-AF-51	4S, 6W, 19	Deseret Peak East	368047	4478729	fusulinid	<i>Pseudofusulinella</i> sp., <i>Triticites</i> sp.	IPobm	Virgilian(?)
S24	78-AF-7	4S, 6W, 30	Deseret Peak East	367882	4478458	fusulinid	<i>Triticites</i> sp.	IPobm	Virgilian(?)
S13	77-AF-25	4S, 6W, 30	Deseret Peak East	637529	4477456	fusulinid	<i>Triticites</i> sp.	IPobm	Virgilian(?)
S21	77-AF-55	4S, 6W, 19	Deseret Peak East	367413	4479546	fusulinid	<i>Triticites</i> sp.	IPobm	Virgilian
S25	78-AF-16	5S, 6W, 16	Deseret Peak East	370974	4471546	fusulinid	<i>Pseudofusulinella</i> sp., <i>Triticites</i> sp.	IPobm	Missourian (?)
S26	78-AF-22	4S, 6W, 19	Deseret Peak East	366728	4478670	fusulinid	<i>Pseudofusulinella</i> sp., <i>Triticites</i> sp.	IPobm	Missourian (?)
S27	78-AF-23	4S, 6W, 31	Deseret Peak East	367562	4476708	fusulinid	<i>Pseudofusulinella</i> sp., <i>Triticites</i> ? sp.	IPobm	Missourian (?)
S4	77-AF-35	5S, 6 W, 8	Deseret Peak East	367782	4474128	fusulinid	<i>Pseudofusulinella</i> sp., <i>Triticites</i> sp.	IPobm	early Missourian?
S5	77-AF-45	5S, 6W, 16	Deseret Peak East	369798	4471544	fusulinid	<i>Pseudofusulinella</i> sp., <i>Triticites</i> sp.	IPobm	early Missourian?
S2	77-AF-18	4S, 7W, -	Deseret Peak East	366423	4478244	fusulinid	<i>Beedeina</i> ? sp.	IPobp	Desmoinesian?
S3	77-AF-21	4S, 7W, -	Deseret Peak East	365855	4479450	fusulinid	<i>Beedeina</i> ? sp.	IPobp	Desmoinesian?
S7	77-AF-88	5S, 6 W, 17	Deseret Peak East	368509	4470762	brachiopod	<i>Mesolobus</i> cf. <i>M. euampygus</i> (Girty)	IPobp	Desmoinesian
S8	78-AF-8	5S, 6W, 20	Johnson Pass	368811	4470140	brachiopod	<i>Mesolobus</i> sp.	IPobp	Middle Pennsylvanian
S10	Seq 6-6	4S, 7 W, -	Deseret Peak East	366052	4477001	fusulinid	<i>Beedeina</i> sp.	IPobp	Desmoinesian
S1	77-AF-13	5S, 6W, 7	Deseret Peak East	367253	4472644	fusulinid	<i>Fusulinella</i> sp.	IPobp	Atokan
S6	77-AF-87	5S, 6W, 17	Deseret Peak East	368390	4470612	fusulinid	<i>Fusulinella</i> sp.	IPobp	Atokan
S9	Seq 5-6	5S, 6 W, 18	Deseret Peak East	367896	4472019	fusulinid	<i>Fusulinella</i> sp.	IPobp	Atokan

Note: Sample locations were obtained from Armin and Moore's (1981) geologic map.
Map unit designations are modified from Armin and Moore (1981).
Fossil identification by C. H. Stevens (USGS).
Wright (1961) also reported fossil data from measured sections in the Stansbury Mountains, but is not included since it lacks detailed location information.

Table 5. Fossil identifications and ages from Rush Valley 30' x 60' quadrangle.

Data from southern Cedar Mountains by Clark and others (2008)

Sample No.	Map Unit	Rock Type	7.5' Quadrangle	Location Data Latitude (N) NAD27	Location Data Longitude (W) NAD27	Fossil Type	Fauna	Preservation & Abrasion	Calcareous Algae Present	Age
D-69	Pofc	biomicrite; wackestone	Tabbys Peak	40°27'48.0"	112°59'49.5"	fusulinid	<i>Triticites</i> cf. <i>T. meeki</i>	Good	None	early Wolfcampian
D-75	Pofc	biomicrite; mudstone	Tabbys Peak	40°28'10.9"	112°59'46.9"	fusulinid	<i>Triticites</i> cf. <i>T. meeki</i>	Fair	None	early Wolfcampian
D-76	IPobm	biomicrite; wackestone	Tabbys Peak	40°29'53.8"	112°58'41.1"	fusulinid	<i>Triticites</i>	Fair	None	Virgilian
D-68	IPobm	biomicrite; wackestone	Tabbys Peak	40°23'37.1"	112°59'45.3"	fusulinid	<i>Triticites</i>	Fair	None	Virgilian
D-52	IPobm	biomicrite; wackestone	Tabbys Peak SW	40°21'18.4"	112°59'14.5"	fusulinid	<i>Pseudofusulinella</i> , <i>Triticites</i>	Fair	None	early Virgilian
D-57	IPobm	bioparite; packstone	Tabbys Peak SW	40°19'31.0"	112°59'13.0"	fusulinid	<i>Triticites cullamensis</i>	Good	None	early Virgilian
D-71	IPobm	biomicrite; mudstone	Tabbys Peak	40°23'05.6"	112°59'05.3"	fusulinid	<i>Triticites</i>	Good	None	Missourian
D-78	IPobm	biomicrite; wackestone	Tabbys Peak SW	40°20'04.3"	112°58'34.9"	fusulinid	<i>Triticites</i>	Fair	None	Missourian
D-70	IPobp	biomicrite; wackestone	Tabbys Peak	40°23'08.4"	112°58'34.7"	fusulinid	<i>Beedeina</i>	Fair	Fragments	early Desmoinesian
D-50	IPowc	crinoidal packstone	Tabbys Peak	40°22'38.9"	112°57'57.4"	conodont	<i>Adetognathus lautus</i>	-	-	latest Mississippian to early Permian

Note: Fusulinids identified by A.J. Wells (independent).
Conodonts identified by S.R. Ritter (Brigham Young University).

Data from Stansbury Mountains, South Mountain, Quirrh Mountains (this study)

				UTM Easting NAD27	UTM Northing NAD27					
RV-17	Pofc	bioparite; packstone	Deseret Peak East	359232	4480292	fusulinid	<i>Triticites</i> cf. <i>T. meeki</i>	Good	None	early Wolfcampian
RV-8	Pofc	bioparite; packstone	Deseret Peak East	370302	4476669	fusulinid	<i>Schwagerina</i> , <i>Triticites</i>	Poor	None	early Wolfcampian
RV-11	IPobm	bioparite; packstone	Deseret Peak East	359812	4476473	fusulinid	<i>Triticites</i>	Poor	None	Virgilian
RV-9	IPobm	biomicrite; wackestone	Deseret Peak East	359355	4476355	fusulinid	<i>Triticites</i> cf. <i>T. Cullamensis</i>	Fair	None	Virgilian
RV-2	IPobm	bioparite; packstone	Deseret Peak East	358510	4481907	fusulinid	<i>Triticites</i>	Fair	None	Virgilian
RV-5	IPobm	wackestone	Deseret Peak East	358234	4481041	fusulinid	<i>Triticites</i>	Good	None	Missourian
RV-4	IPobm	biomicrite; wackestone	Deseret Peak East	358054	4481089	fusulinid	<i>Propseudofusulinella</i>	Fair	None	Missourian
RV-6	IPobm	sandstone	Deseret Peak East	367964	4480377	fusulinid	<i>Propseudofusulinella</i>	Good	None	Missourian
RV-14	Pdk	bioparite; grainstone	South Mountain	376615	4480605	fusulinid	<i>Schwagerina</i>	Fair-Poor	None	late-early Wolfcampian
RV-15	Pocp	biomicrite; mudstone	South Mountain	380540	4481840	fusulinid	<i>Triticites</i> , <i>Schwagerina</i>	Poor	None	Wolfcampian
970	IPobm	biomicrite; mudstone	South Mountain	379150	4481088	fusulinid	<i>Triticites</i>	Fair	None	late Missourian to Virgilian
1199	IPobm	calcareous sandstone	South Mountain	378298	4473295	fusulinid	<i>Triticites</i>	Poor	None	Missourian
RV-20	IPobm	calcareous sandstone	South Mountain	380650	4478875	fusulinid	<i>Triticites</i>	Poor	None	early Missourian
RV-18	IPobm	wackestone	South Mountain	381603	4479643	fusulinid	<i>Propseudofusulinella</i>	Good	None	Missourian
RV-28	IPobm	limestone	South Mountain	382228	4479232	conodont	ideognathodids and/or adetognathids	-	-	Pennsylvanian
RV-27	IPobm	limestone	South Mountain	382399	4479227	conodont	ideognathodids and/or adetognathids	-	-	Pennsylvanian
969	IPobp	biomicrite; wackestone	South Mountain	382403	4478628	fusulinid	<i>Fusulina</i>	Poor	None	early Desmoinesian
RV-23	IPobp	calcareous sandstone	Stockton	388761	4480243	fusulinid	<i>Fusulinella</i>	Fair	None	late Atokan
RV-22	IPobp	mudstone	Stockton	359009	4479246	fusulinid	<i>Fusulinella</i>	Poor	None	late Atokan
RV-31	IPowc	limestone	Low Peak	355986	4471439	conodont	ideognathodids and/or adetognathids	-	-	Pennsylvanian

Data from Vernon Hills by Kirby (2010a, b) and this study.

				UTM Easting NAD83	UTM Northing NAD83					
447	IPobm	biomicrite; wackestone	Faust	381793	4443254	fusulinid	<i>Triticites</i> cf. <i>T. cullamensis</i>	Good	None	middle-early Virgilian
720	IPobm	biomicrite; wackestone	Lofgreen	383341	4441425	fusulinid	<i>Pseudofusulinella</i>	Fair	None	late Missourian through Virgilian
726	IPobm	biomicrite; wackestone	Lofgreen	383624	4441112	fusulinid	<i>Pseudofusulinella</i> ; <i>P. cf. forausonianensis</i>	Fair	None	Missourian through earliest Wolfcampian
245	IPobp	biomicrite; mudstone	Lofgreen	383106	4440395	fusulinid	<i>Protusulinella</i>	Good	None	early Atokan
586	IPowc	biomicrite; wackestone	Vernon	382282	4439530	fusulinid	-	Poor	None	Morrowan?

Note: Fusulinids identified by A.J. Wells (independent).
Conodonts identified by S.M. Ritter (Brigham Young University).

CORRELATION OF QUATERNARY GEOLOGIC UNITS
Rush Valley 30' x 60' Quadrangle (year 2)

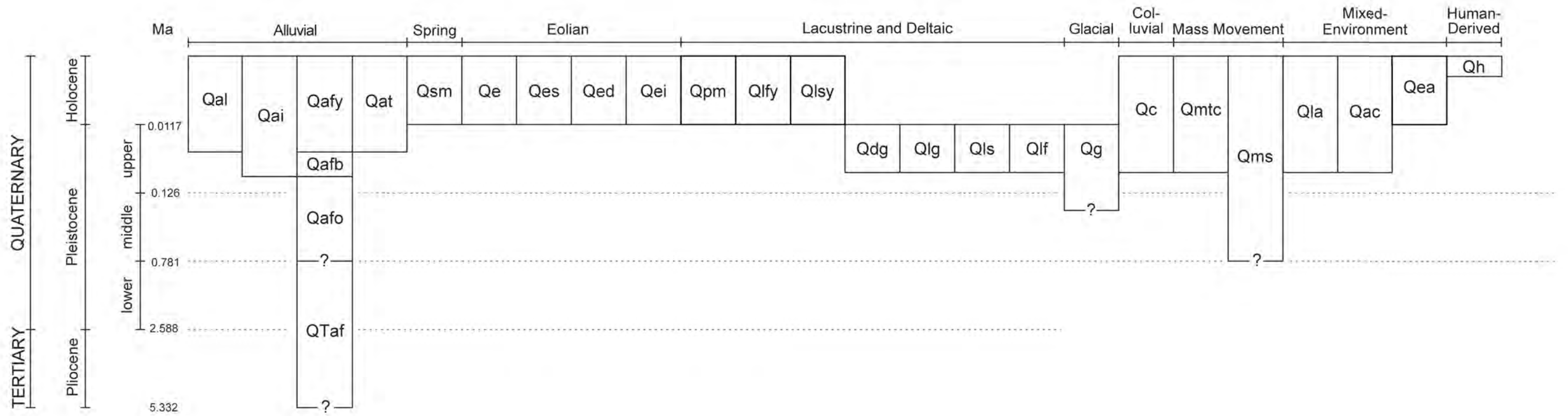

CORRELATION OF MESOZOIC, PALEOZOIC, AND PRECAMBRIAN GEOLOGIC UNITS

Rush Valley 30' x 60' Quadrangle (year 2)

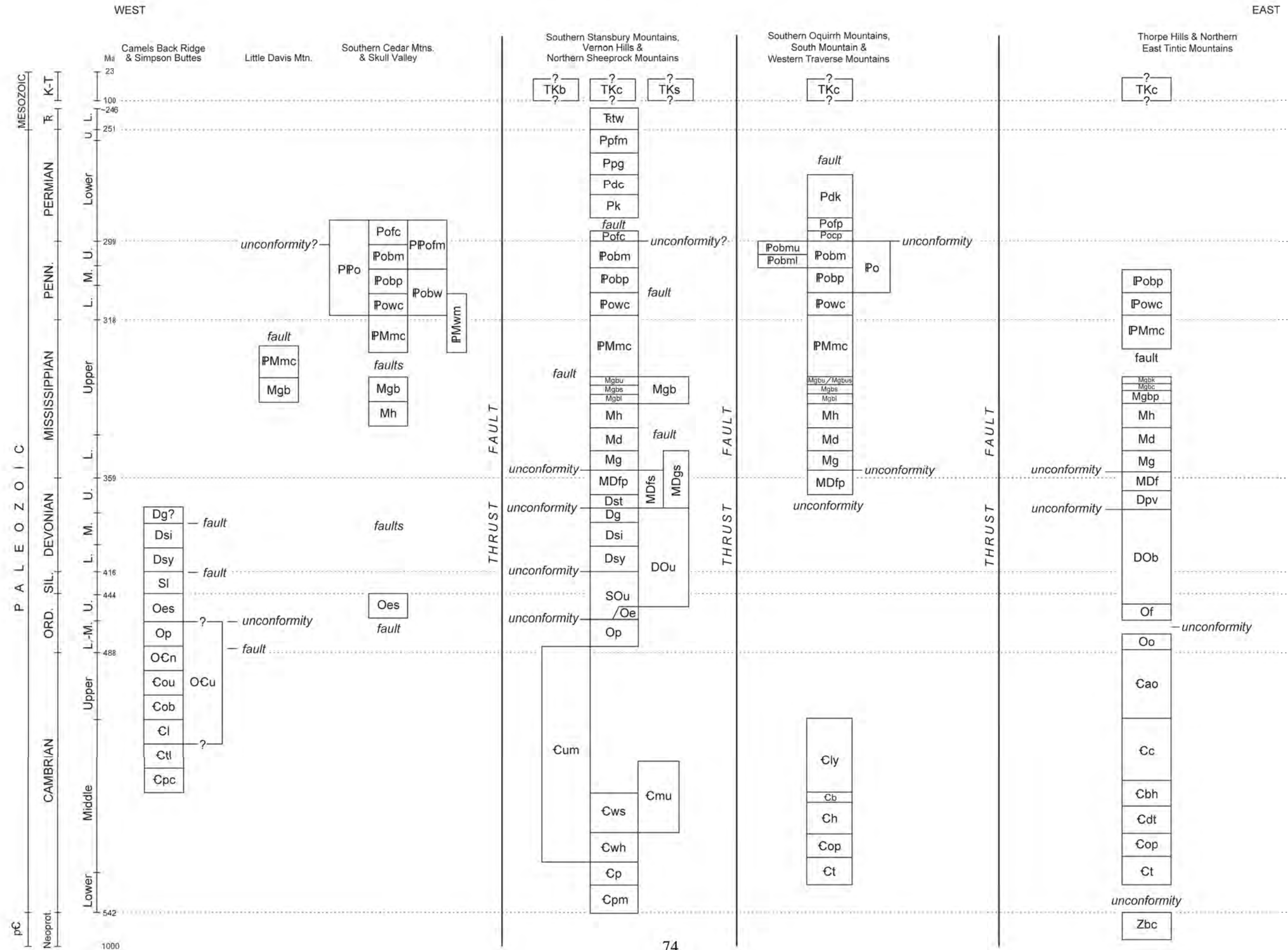

LITHOLOGIC COLUMN
Camels Back Ridge and Simpson Buttes

TIME-STRATIGRAPHIC UNIT	GEOLOGIC UNIT	MAP SYMBOL	THICKNESS Feet (Meters)	LITHOLOGY
DEVONIAN	M. & U.	Dg?	500+ (150+)	
FAULT				
DEVONIAN	Middle	Dsj	500+ (150+)	
	Lower	Dsy	250 (75)	Light, laminated dolomite
FAULT				
ORDOVICIAN		Sl	500+ (150+)	Cherty
	Upper	Oes	250 (75)	Light dolomite - Floride unit
	M. & L.	Op Ocu	150+ (45+)	Unconformity - Tooele Arch
FAULT				
CAMBRIAN	Upper	Notch Peak Formation Ocn	500+ (150+)	Cliffs
		Or Formation	200 (60)	
		upper part Big Horse Limestone Member Cob	425 (130)	
	?	Lamb Dolomite Cl	900 (275)	Upper - less resistant, rusty and pink weathering
		2300 (700)		
	Middle	Trippe Limestone Ctl	700 (215)	Less resistant and ledgy
Pierson Cove Formation Cpc		800+ (245+)	Locally dolomitized	

LITHOLOGIC COLUMN

Little Davis Mountain

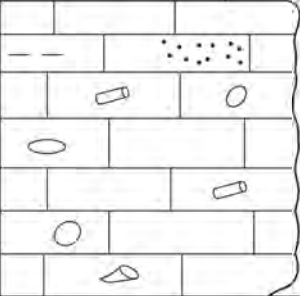
TIME-STRATI-GRAPHIC UNIT	GEOLOGIC UNIT	MAP SYMBOL	THICKNESS Feet (Meters)	LITHOLOGY	
Onaqui fault					
MISSISSIPPIAN	Upper	Manning Canyon Shale	PMmc	200+ (60+)	
		Great Blue Limestone	Mgb	1200+(370+)	

LITHOLOGIC COLUMN
Southern Cedar Mountains, Skull Valley

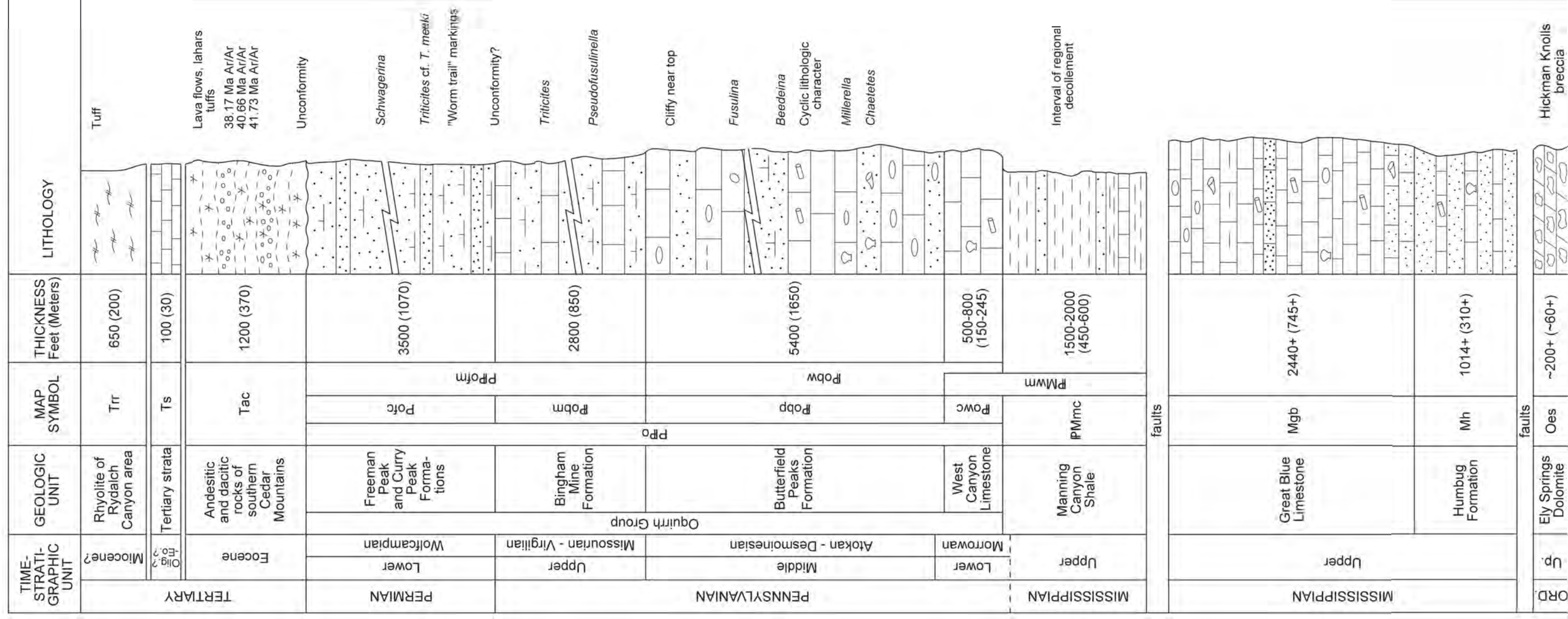

LITHOLOGIC COLUMN

Southern Oquirrh Mountains, South Mountain, Western Traverse Mountains

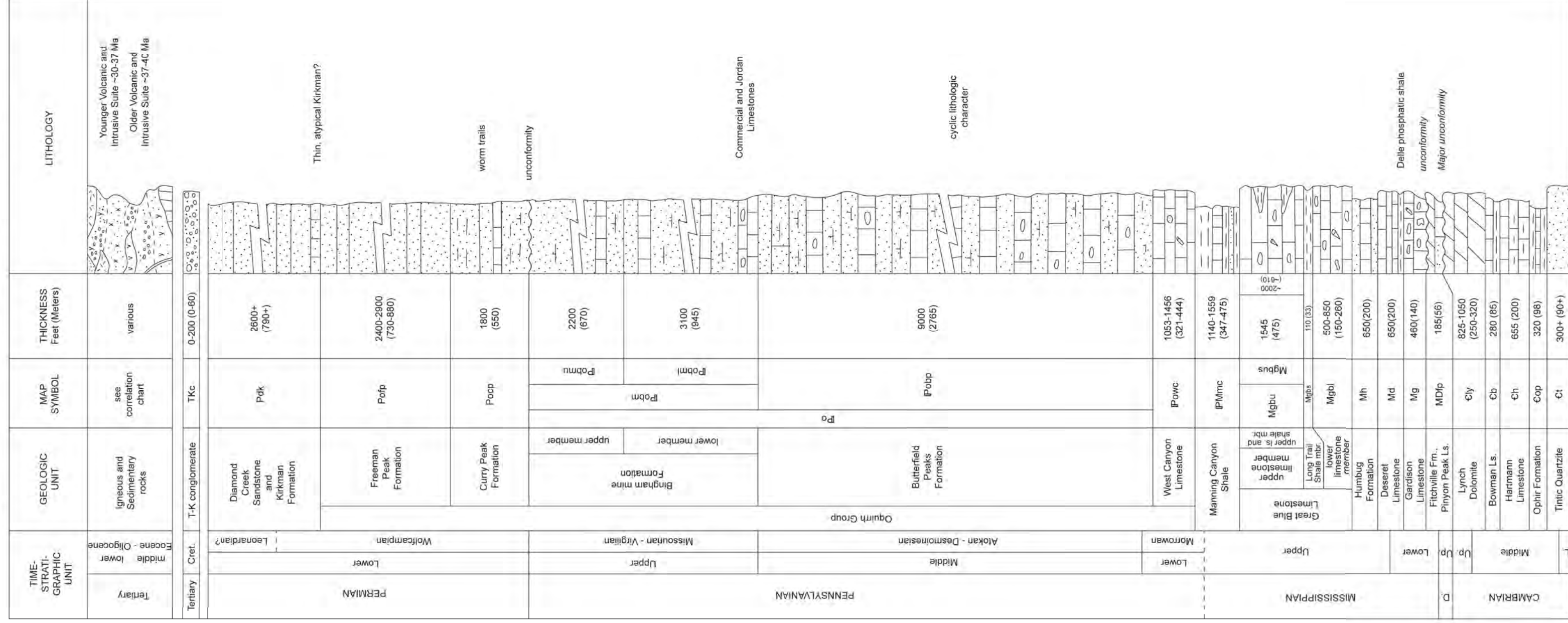

Thin, atypical Kirkman?

worm trails

unconformity

Commercial and Jordan Limestones

cyclic lithologic character

Dele phosphatic shale
unconformity
Major unconformity

LITHOLOGIC COLUMN

Southern Stansbury Mountains, Vernon Hills, Northern Sheeprock Mountains

TIME-STRATIGRAPHIC UNIT	GEOLOGIC UNIT	MAP SYMBOL	THICKNESS FEET (METERS)	LITHOLOGY				
TERTIARY	Miocene?	see correlation chart	various					
	Eocene?							
PERMIAN	Lower	Pdc	350 (105)					
					Ppg	500 (150)		
PERMIAN	Upper	Ppfm	510 (155)					
					TKb, TKc, TKs	0->2200 (0->670)		
TRIASSIC	L	TKw	800 (245)					
PENNSYLVANIAN	Lower	Pofc	3500+ (1100+)					
					Upper	Pobm	8000 (2450)	
	Middle	Quirth Group	Freeman Peak and Curry Peak Formations					
					Upper	Missourian - Virgilian	Bingham Mine Formation	
	Upper	Atokan - Desm.	Butterfield Peaks Formation					
					MISSISSIPPIAN	Lower	Powc	1150-1650 (350-500)
	Upper	IPmirc	0-1300 (400)					
						Upper	Mgb	800 (240)
	Upper	Mgb	30-80 (10-25)					
Upper						Mgbl	700-820+ (210-250+)	
	Upper	Mh	700-1250 (210-380)					
Lower						Md	525 (160)	
	Lower	Mg	700-840 (210-260)					
Upper						MDfp	60-200 (20-60)	
	Upper	Dst	0-200 (60)					
Upper					Dg	180 (50)		
	Upper	Dsi	570-890 (170-270)					
Upper					Dsy	710-830 (220-250)		
	Upper	SOu	1060-1280(320-390)					
Upper					Oe	0-80 (25)		
	Upper	Op	0-1350 (410)					
Upper					€um	~1500-5000 (~450-1500)		
	Middle	€ws	720 (220)					
Middle					€wh	880 (360)		
	Middle	€p	300 (90)					
Lower					€pm	4200+ (1280+)		
	Upper	upper and middle Cambrian strata	Wheeler Formation, Swasey Ls.					
Upper					Whirlwind Fm., Dome Ls., Chisholm Fm., Howell Ls.	Pioche Formation		
	Upper	Eureka Quartzite	Pogonip Group					
Upper					Laketown Dolomite, Ely Springs Dolomite	Sevy Dolomite		
	Upper	Simonson Dolomite	Fitchville Formation, Pinyon Peak Limestone					
Upper					Stansbury Fm. Gilmette Fm.	Gardison Limestone		
	Upper	Humbug Formation	Deseret Limestone					
Upper					Great Blue Limestone	Manning Canyon Shale		
	Upper	upper limestone mbr. Long Trail Shale Mbr. lower Limestone mbr.	West Canyon Limestone					
Upper					Morrowan	West Canyon Limestone		

unconformity?

fault in Vernon Hills

faults in Stansbury Mtns. and Vernon Hills

fault in Vernon Hills

fault in Vernon Hills

unconformity

unconformity - Stansbury uplift

unconformity

unconformity where Eureka absent

LITHOLOGIC COLUMN

Southern Stansbury Mountains, Vernon Hills, Northern Sheeprock Mountains

TIME-STRATIGRAPHIC UNIT	GEOLOGIC UNIT	MAP SYMBOL	THICKNESS FEET (METERS)	LITHOLOGY	
TERTIARY	Miocene?	see correlation chart	various		
	Eocene?				
PERMIAN	Tertiary - Cret.	TKb, TKc, TKs	0->2200 (0->670)		
	TRASSIC	Thaynes Limestone, Woodside Fm.	800 (245)		
PERMIAN	Upper	Park City Phosph. Fms.	510 (155)		
		Franson Mbr., Meade Pk. Sh., Grandeur Mbr.	500 (150)		
	Lower	Diamond Creek Ss.	350 (105)		
		Kirkman Formation	400 (120)		
		Qquirth Group			
PERMIAN	Lower	Freeman Peak and Curry Peak Formations	3500+ (1100+)		
	Upper	Bingham Mine Formation	8000 (2450)		
	Middle	Butterfield Peaks Formation	8000+ (1800+)		
PENNSYLVANIAN	Upper	Atokan - Desm.			
	Lower	Wolfcampian			
MISSISSIPPIAN	Upper	West Canyon Limestone	1150-1650 (350-500)		
		Manning Canyon Shale	0-1300 (400)		
	Upper	Great Blue Limestone	Mgb		800 (240)
		upper limestone mbr.	Mgbu		30-80 (10-25)
		Long Trail Shale Mbr., lower limestone mbr.	Mgbs, Mgbl		700-820+ (210-250+)
	Upper	Humbug Formation	Mh		700-1250 (210-380)
		Deseret Limestone	Md		525 (160)
	Lower	Gardison Limestone	Mg		700-840 (210-260)
		Fitchville Formation, Pinyon Peak Limestone	MDfp, MDfs		60-200 (20-60)
	Upper	Stansbury Fm., Gilmette Fm.	Dst, Dg		0-200 (60)
		Simonson Dolomite	Dsi		180 (50)
		Sevy Dolomite	Dsy		570-890 (170-270)
Middle	Laketon Dolomite, Ely Springs Dolomite	SOu	710-830 (220-250)		
	Eureka Quartzite	Oe	1060-1280(320-390)		
Lower	Pogonip Group	Op	0-80 (25)		
			0-1350 (410)		
CAMBRIAN	Upper	upper and middle Cambrian strata	~1500-5000 (~450-1500)		
		Wheeler Formation, Swasey Ls., Whirlwind Fm., Dome Ls., Chisholm Fm., Howell Ls., Ploche Formation	€um, €ws, €wh, €p		
	Middle		~1500 (~450)		
			720 (220), 880 (360), 300 (90)		
Lower	Prospect Mountain Quartzite	€pm	4200+ (1280+)		

unconformity?

fault in Vernon Hills

faults in Stansbury Mtns. and Vernon Hills

fault in Vernon Hills

fault in Vernon Hills

unconformity











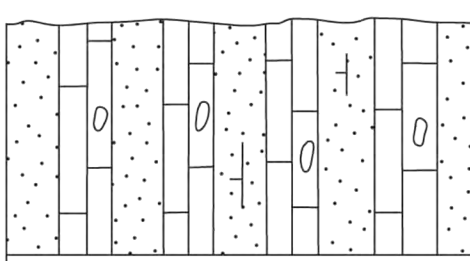
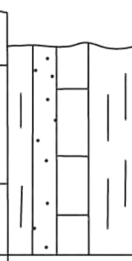



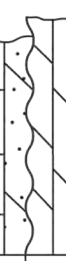

unconformity - Stansbury uplift

unconformity

unconformity where Eureka absent

LITHOLOGIC COLUMN

Thorpe Hills and Northern East Tintic Mountains

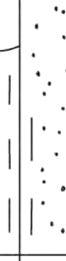
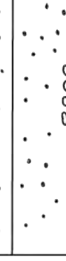
TIME-STRATIGRAPHIC UNIT	GEOLOGIC UNIT	MAP SYMBOL	THICKNESS FEET (METERS)	LITHOLOGY	
Tertiary	Miocene -upper Eocene	see correlation chart	various	 Basalt 19.5 Ma ~30-35 Ma	
	Tertiary - Cret.				TKc
PENNSYLVANIAN	Middle	Oquirrh Group	3650+ (1110+)	 Butterfield Peaks Formation	
					Lower
		Morrowan	IPowc	1050 (320)	 Manning Cayon Shale
			IPMmc		
MISSISSIPPIAN	Upper	Great Blue Formation	600 (180)	 Poker Knoll Ls. Mbr.	
			850 (260)	 Chiulos Shale Mbr.	
			1080 (330)	 Paymaster Mbr.; Topliff Ls. Mbr.	
		600 (180)	Humbug Formation		
		700 (215)	Deseret Limestone		
		450 (140)	Gardison Limestone		
	Lower	Fitchville Formation	Mdf	300 (90)	 Fitchville Formation
				250-300 (75-90)	 Pinyon Peak Ls., Victoria Fm.
				600 (180)	 Bluebell Dolomite
	D.	Fish Haven Dol.	Of	270 (80)	 Fish Haven Dol.
				800 (245)	 Opohonga Limestone
				850 (260)	 Ajax Dolomite, Opex Formation
ORD.	Lower	€ao	825 (250)	 Cole Canyon Dolomite	
			600 (180)	 Bluebird Dol., Herkimer Ls.	
			500 (150)	 Dagmar Dol., Teutonic Ls.	
			430 (130)	 Ophir Formation	
				 Tintic Quartzite	
CAMBRIAN	Middle	€cc	2500 (760)	 Tintic Quartzite	
				 Big Cottonwood Fm.	
Neoproterozoic		Zbc	200+ (60+)	 Big Cottonwood Fm.	

unconformity

unconformity

unconformity

unconformity

GEOLOGIC SYMBOLS

	Contact – Angled where scratch
	Normal fault, concealed – Inferred principally from gravity data; bar and ball on down-thrown side
	Steeply dipping fault – Dashed where inferred, dotted where concealed; bar and ball and/or arrows indicate relative displacement if known
	Thrust fault – Dashed where inferred, dotted where concealed; teeth on hanging wall
	Attenuation fault – Dotted where concealed; boxes on hanging wall
	Low-angle normal fault – Dotted where concealed; boxes on hanging wall
	Lineament – From air photo interpretation
	Igneous dike (map unit Tqli)
	Igneous dike (map unit Tdio)
	Igneous dike (map unit Tpqmi)
	Igneous dike (map unit Tri)
	Axial trace of anticline – Dashed where approximately located, dotted where concealed; arrow shows plunge
	Axial trace of overturned anticline – Dashed where approximately located, dotted where concealed; arrow shows plunge
	Axial trace of syncline – Dashed where approximately located, dotted where concealed; arrow shows plunge
	Axial trace of overturned syncline – Dashed where approximately located, dotted where concealed; arrow shows plunge
	Major shorelines of the Bonneville lake cycle (see table 1) –
	Bonneville shoreline
	Provo shoreline
	Shambip shoreline
	Smelter Knolls shoreline
	Stansbury shoreline
	other transgressive and regressive shorelines
	Lake Bonneville crest of barrier ridge or delta ridge
	Delta distributary channel crest
	Holocene shoreline of Rush Lake
	Strike and dip of bedding (refer to index map for prior mapping sources) –
	Inclined from current mapping
	Inclined from Clark and others (2008)
	Inclined from prior mapping
	Inclined approximate from Clark and others (2008)
	Vertical from current mapping
	Vertical from prior mapping
	Overturned from current mapping
	Overturned from prior mapping
	Sand and gravel pit
	Mine or quarry
	Mine or adit
	Shaft
	Drill hole
	Rock sample location and number for geochemical analyses and Ar/Ar age (see tables 2, 4)
	Rock sample location and number for prior Ar/Ar age analyses (see table 4)
	Rock sample location and number for geochemical analyses (see table 2)
	Tephra sample location and number for geochemical analyses and age (see table 3)
	Fossil sample location and number for age evaluation (see table 5)
Qed\Qlf	Indicates thin cover of the first unit overlying the second unit

LITHOLOGIC COLUMN

Thorpe Hills and Northern East Tintic Mountains

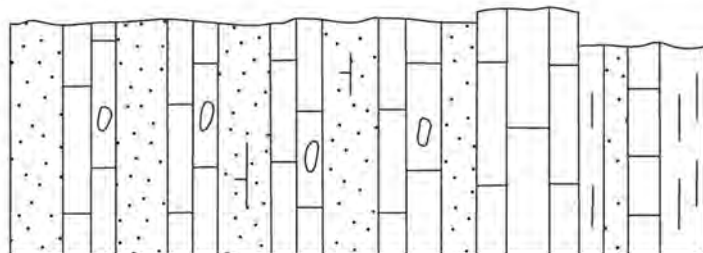
TIME-STRATIGRAPHIC UNIT	GEOLOGIC UNIT	MAP SYMBOL	THICKNESS FEET (METERS)	LITHOLOGY	
Tertiary	Miocene -upper Eocene	see correlation chart	various	 <p>Basalt 19.5 Ma ~30-35 Ma</p>	
	Tertiary - Cret.				TKc
PENNSYLVANIAN	Middle	Oquirrh Group	3650+ (1110+)	 <p>Butterfield Peaks Formation</p>	
					Lower
		Morrowan	IPMmc	1050 (320)	Manning Cayon Shale
					fault
MISSISSIPPIAN	Upper	Poker Knoll Ls. Mbr.	600 (180)	Mgbk	
		Chiuos Shale Mbr.	850 (260)	Mgbc	
		Paymaster Mbr.; Topliff Ls. Mbr.	1080 (330)	Mgbp	
		Humbug Formation	600 (180)	Mh	
		Deseret Limestone	700 (215)	Md	
	Lower	Gardison Limestone	450 (140)	Mg	
		Fitchville Formation	300 (90)	MDf	
		Pinyon Peak Ls., Victoria Fm.	250-300 (75-90)	Dpv	
		Bluebell Dolomite	600 (180)	SOB	
		Fish Haven Dol.	270 (80)	Of	
ORD.	Lower	Opohonga Limestone	800 (245)	Oo	
		Ajax Dolomite, Opex Formation	850 (260)	€ao	
		Cole Canyon Dolomite	825 (250)	€c	
CAMBRIAN	Middle	Bluebird Dol., Herkimer Ls.	600 (180)	€bh	
		Dagmar Dol., Teutonic Ls.	500 (150)	€dt	
		Ophir Formation	430 (130)	€op	
	Lower	Tintic Quartzite	2500 (760)	€t	
Neoproterozoic	Big Cottonwood Fm.	Zbc	200+ (60+)	unconformity	

GEOLOGIC SYMBOLS

	Contact – Angled where scratch
	Normal fault, concealed – Inferred principally from gravity data; bar and ball on down-thrown side
	Steeply dipping fault – Dashed where inferred, dotted where concealed; bar and ball and/or arrows indicate relative displacement if known
	Thrust fault – Dashed where inferred, dotted where concealed; teeth on hanging wall
	Attenuation fault – Dotted where concealed; boxes on hanging wall
	Low-angle normal fault – Dotted where concealed; boxes on hanging wall
	Lincament – From air photo interpretation
	Igneous dike (map unit Tqli)
	Igneous dike (map unit Tdio)
	Igneous dike (map unit Tpqmi)
	Igneous dike (map unit Tri)
	Axial trace of anticline – Dashed where approximately located, dotted where concealed; arrow shows plunge
	Axial trace of overturned anticline – Dashed where approximately located, dotted where concealed; arrow shows plunge
	Axial trace of syncline – Dashed where approximately located, dotted where concealed; arrow shows plunge
	Axial trace of overturned syncline – Dashed where approximately located, dotted where concealed; arrow shows plunge
	Major shorelines of the Bonneville lake cycle (see table 1) –
	Bonneville shoreline
	Provo shoreline
	Shambip shoreline
	Smelter Knolls shoreline
	Stansbury shoreline
	other transgressive and regressive shorelines
	Lake Bonneville crest of barrier ridge or delta ridge
	Delta distributary channel crest
	Holocene shoreline of Rush Lake
	Strike and dip of bedding (refer to index map for prior mapping sources) –
	Inclined from current mapping
	Inclined from Clark and others (2008)
	Inclined from prior mapping
	Inclined approximate from Clark and others (2008)
	Vertical from current mapping
	Vertical from prior mapping
	Overturned from current mapping
	Overturned from prior mapping
	Sand and gravel pit
	Mine or quarry
	Mine or adit
	Shaft
	Drill hole
	Rock sample location and number for geochemical analyses and Ar/Ar age (see tables 2, 4)
	Rock sample location and number for prior Ar/Ar age analyses (see table 4)
	Rock sample location and number for geochemical analyses (see table 2)
	Tephra sample location and number for geochemical analyses and age (see table 3)
	Fossil sample location and number for age evaluation (see table 5)
	Qed\Qlf Indicates thin cover of the first unit overlying the second unit

**PROGRESS REPORT GEOLOGIC MAP OF THE
 RUSH VALLEY 30' X 60' QUADRANGLE,
 TOOELE, UTAH, AND SALT LAKE COUNTIES,
 UTAH
 (YEAR 2 OF 3)**

by
Donald L. Clark¹, Stefan M. Kirby¹, and Charles G. Oviatt²
¹ Utah Geological Survey, P.O. Box 146009, Salt Lake City, UT 84114-0109
² Department of Geology, Kansas State University, Manhattan, KS 66506-2301

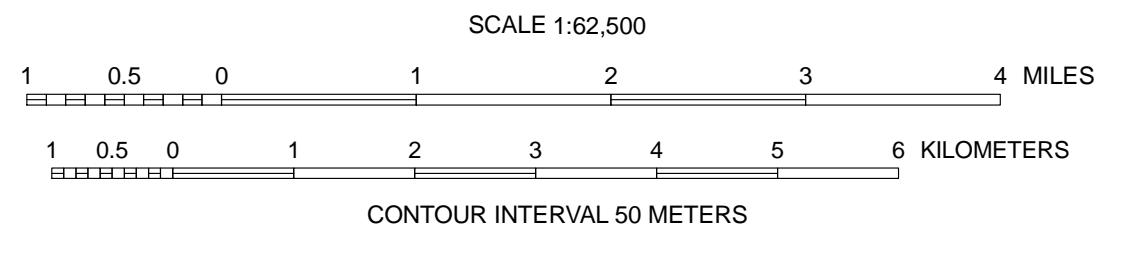

This open file report provides the public with the results of the second year of mapping of a geologic map. The map is for informational purposes only and does not constitute a warranty of any kind. The Utah Geological Survey is not responsible for any errors or omissions in the map. The map is for informational purposes only and does not constitute a warranty of any kind. The Utah Geological Survey is not responsible for any errors or omissions in the map. The map is for informational purposes only and does not constitute a warranty of any kind. The Utah Geological Survey is not responsible for any errors or omissions in the map.

Geologic Units

Unit	Symbol	Color	Unit	Symbol	Color
Qh	Qh	Light Gray	Tsw	Tsw	Red
Ce	Ce	Yellow	Tvls	Tvls	Blue
Qes	Qes	Light Green	Tvlsb	Tvlsb	Dark Blue
Qed	Qed	Light Yellow	Tlsl	Tlsl	Purple
Qei	Qei	Light Green	Tlsa	Tlsa	Dark Purple
Qsm	Qsm	Light Green	Tlst	Tlst	Dark Purple
Qpm	Qpm	Light Green	Tlst?	Tlst?	Dark Purple
Qlty	Qlty	Light Green	Tvfa	Tvfa	Blue
Qes/Qla	Qes/Qla	Light Green	Tsb	Tsb	Blue
Qes/Qafy	Qes/Qafy	Light Green	Tsb?	Tsb?	Blue
Qed/Qla	Qed/Qla	Light Green	Tsc	Tsc	Blue
Qel/Qal	Qel/Qal	Light Green	Tlir	Tlir	Blue
Qel/Qlf	Qel/Qlf	Light Green	Tp	Tp	Blue
Qes/Qaf	Qes/Qaf	Light Green	Tai	Tai	Blue
Qed/Tac	Qed/Tac	Light Green	Tpqrmi	Tpqrmi	Blue
Qal	Qal	Light Green	Tli	Tli	Blue
Qai	Qai	Light Green	Tami	Tami	Blue
Qat	Qat	Light Green	Tac	Tac	Blue
Qas	Qas	Light Green	Tvfo	Tvfo	Blue
Qms	Qms	Light Green	Tdv	Tdv	Blue
Qms?	Qms?	Light Green	Trv	Trv	Blue
Qatb	Qatb	Light Green	Tmi	Tmi	Blue
Qdg	Qdg	Light Green	Tdi	Tdi	Blue
Qlg	Qlg	Light Green	Tvlo	Tvlo	Blue
Qls	Qls	Light Green	Tvfo	Tvfo	Blue
Qlf	Qlf	Light Green	Tvfo	Tvfo	Blue
Qlf/Qls	Qlf/Qls	Light Green	Tsu	Tsu	Blue
QlglR	QlglR	Light Green	Tqli	Tqli	Blue
QlglMh?	QlglMh?	Light Green	Tqli?	Tqli?	Blue
Qg	Qg	Light Green	Tvs	Tvs	Blue
Qg?	Qg?	Light Green	Tbi	Tbi	Blue
Qaf	Qaf	Light Green	Taci	Taci	Blue
Qaf?	Qaf?	Light Green	TKc	TKc	Blue
Qaf?	Qaf?	Light Green	TKs	TKs	Blue
Tj	Tj	Red	Ttw	Ttw	Blue
Tvm	Tvm	Blue	Ppfm	Ppfm	Blue
Tdm	Tdm	Blue	Ppg	Ppg	Blue
Tb	Tb	Blue	Ppk	Ppk	Blue
Ts	Ts	Blue	Pdk?	Pdk?	Blue
Tpc	Tpc	Blue	Pdc	Pdc	Blue
TKb	TKb	Blue	Pk	Pk	Blue
Tvbs	Tvbs	Blue	PPo	PPo	Blue
Tvls	Tvls	Blue	PPoM	PPoM	Blue
Tf	Tf	Blue	Pofc	Pofc	Blue
Tni	Tni	Blue	Pofp	Pofp	Blue
Tri?	Tri?	Blue	Pofp?	Pofp?	Blue
			Pocp	Pocp	Blue
			Po	Po	Blue
			Pobm	Pobm	Blue
			Pobm?	Pobm?	Blue
			Pobmu	Pobmu	Blue
			Pobml	Pobml	Blue
			Pobw	Pobw	Blue
			Pobp	Pobp	Blue
			PMmw	PMmw	Blue
			Powc	Powc	Blue
			Powc?	Powc?	Blue
			PMmc	PMmc	Blue
			PMmc?	PMmc?	Blue
			Mgb	Mgb	Blue
			Mgbu	Mgbu	Blue

